

REGOZ  
audio

ANTI-VIBRATION AUDIO STAND



# ROGOZ a u d i o

Rogoz Audio manufactures specialist anti-vibration furniture: audio stands, speaker stands, and platforms. Our offer is aimed primarily at audiophiles, music lovers, and music business professionals, as well as all those who appreciate high quality of sound and design. Our ultimate goal is creating products eliminating interference between audio components to make it possible for every audio system to reach its maximum effectiveness so that the listeners will enjoy the best possible sound quality.

The furniture and anti-vibration accessories are designed for top quality audio components. A whole structure has been tuned by means of special blending of alloy steel and high carbon content steel. Decoupling and high-precision leveling is achieved by means of adjustable anti-vibration spikes. Some furniture incorporates soft anti-vibration pads to separate parts of the overall structure.

A unique feature of our company is extreme flexibility. Certain modifications are possible and as a result each product is manufactured on a made-to-order basis. Alterations of our standard products are priced individually. Possible changes involve:

- all sizes
- the kind of frames of audio and speaker stands
- the kind of tops and shelves of audio stands
- the shape of speaker stand tops
- the kind of decoupling
- colors

## BBS SYSTEM

The structure of some audio stands incorporates a new proprietary Rogoz Audio antivibration system, BBS (Balancing Board System, Patent P.404137). The system consists of a threaded, height-adjustable spike made of high-fiber-content steel alloy, on top of which two elements are placed, each with an inner bearing. An intermediary (middle) element is made of carbon fiber and supports another element, a steel bearing inserted into the shelf. Point contact between the steel spike and the carbon intermediary element prevents movement of either element relative to its axis, but it allows pendular motion. Meanwhile, the contact between the intermediary element and the bearing inserted into the shelf allows restricted rolling motion and sliding motion. Consequently, the advantages of spike point support (contact area has been minimized and kinetic energy turns into heat) have been combined with the effects of deadening vibrations owing to sliding friction and rolling resistance.



**BOARD BALANCING INVOLVES  
HORIZONTAL PLANE MOVEMENT  
IN ALL DIRECTIONS**

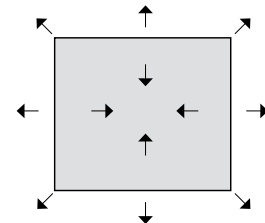
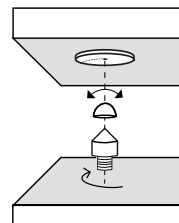

## NATURAL VENEER USER MANUAL

Wood veneer is a natural product, and its pattern, hue or tint might vary slightly, just like individual same-species trees in a forest differ from one another (depending on their age and environment factors influencing tree growth, like the soil's chemical properties, local climate, sun exposure, etc.) This is why producing every piece of furniture or furniture set covered with wood veneer always requires veneer obtained from the same tree trunk.

If, on a future occasion, one chooses the same kind of veneer to match already existing furniture, there will always be noticeable hue and pattern differences. Those differences usually tend to diminish with the passage of time, due to color darkening and the patina that wood acquires, which are natural processes. Newly laid veneer on furniture undergoes a natural process of darkening caused by sunlight and atmospheric gases - mainly during the first eight weeks. This is especially noticeable with cherry, walnut, and oak veneer, but it can also be present with all other kinds, to various degrees. In the areas

with no light exposure, the veneer will remain lighter. This is the case especially in the early stages of using veneered furniture. While the furniture is being used, it is highly advisable to regularly move around the objects placed on it, in order to obtain a uniform color tone of the veneer (and consequently to avoid light patches shaped like the objects placed on a veneered surface).

Due to the same wood characteristic, it might take quite some time before its hue gets to harmonize with older objects made of the same material. Proper wood care requires soft and slightly damp dust cloth. Veneer must be prevented from long-term exposure to water, so a wet cloth should not be left lying on veneer. Wooden surfaces need to be protected from damage by means of special pads, preventing direct contact with materials that might be harmful from a chemical or mechanical point of view (e.g. coloring materials or sharp-edged objects).



modification according to individual requests  
size change, kind of frame,  
kind of shelves, kind of decoupling



SYSTEM



<https://www.rogoz-audio.com>  
office@rogoz-audio.com  
januszrogoz@yahoo.pl

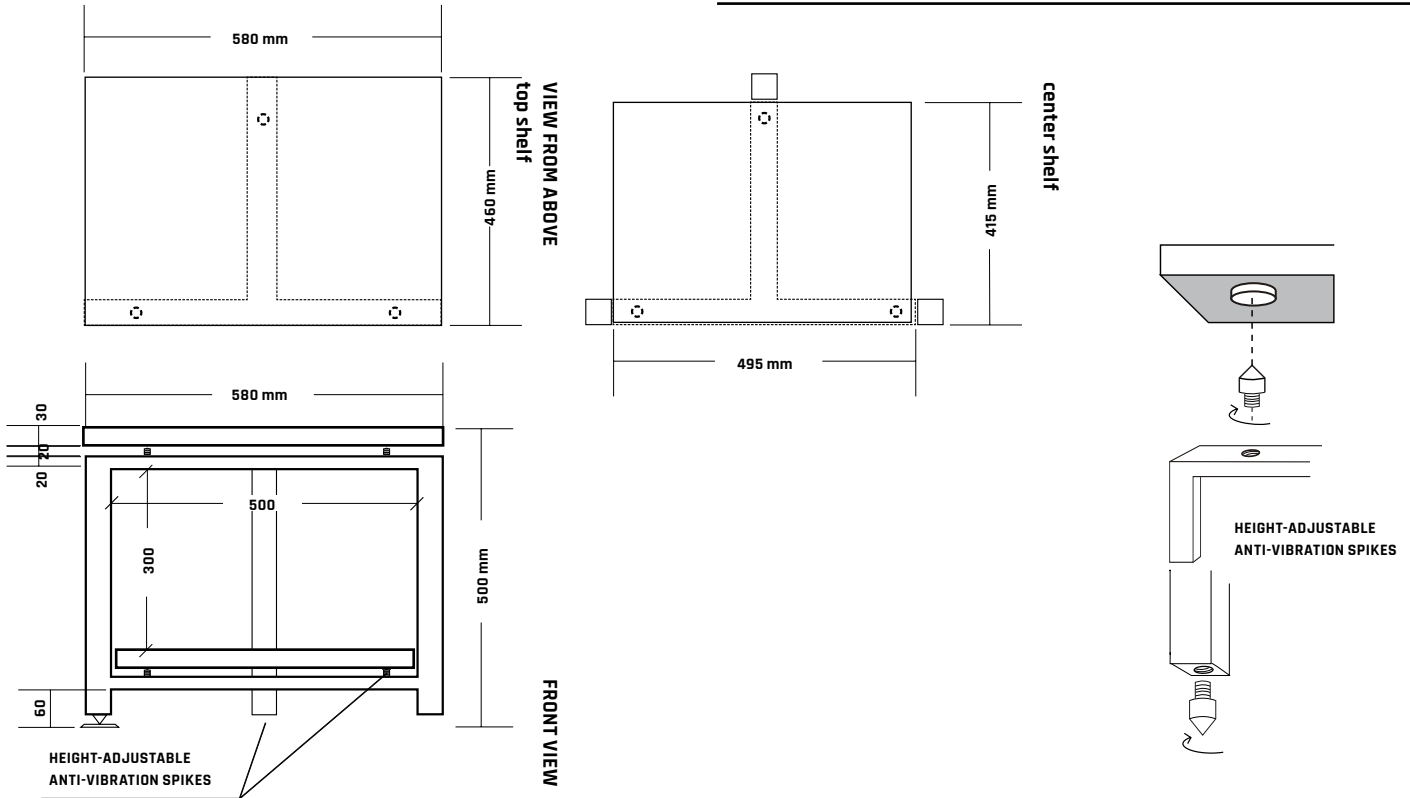

### TECHNICAL DESCRIPTION

- Overall height: 500 mm;
- Overall width: 580 mm;
- Overall depth: 460 mm;
- Leg profile: 40 x 40 mm;
- Top shelf: 580 x 460 x 30 mm;
- Bottom shelf: 495 x 415 x 30 mm;
- Usable distance between the shelves: 300 mm;
- Maximum load for each shelf: up to 50 kg (total: 100 kg)

### A COMPLETE SET INCLUDES

- 1 steel frame;
- 2 shelves (MDF/HDF/MDF SANDWICH STRUCTURE);
- 9 height-adjustable spikes;
- 6 anti-vibration separating disks;
- 3 anti-scratch disks protecting the floor

### APPLICATION

- CD players
- turntables
- integrated amplifiers
- preamplifiers
- power amplifiers
- DACs

Three-leg, two-level design. Sandwich-structured shelves finished in black matte.

The frame is designed for quartz sand filling – threaded openings located at the rear of the legs allow adjustment of both the amount and type of ballast. Frame finish: black matte (fine texture).

**The Fras Svart is designed for compact audio systems, offering a rigid three-leg structure that ensures precise bass control and stable sound imaging.**

### Vibration control and mechanical stability

Rogoz Audio racks are designed as systems that control the flow of mechanical energy. In the Fras Svart model, the key elements are mass, structural rigidity, and point-based support.

The structure is tuned through the deliberate combination of different steel types. The frame consists of thick-walled legs made of S235JR carbon steel and crossbars made of high-strength S355 alloy steel.

The sandwich-structured shelves (MDF/HDF/MDF) feature varied density and internal structure, promoting dissipation and damping of vibrational energy rather than its accumulation.

Point support on adjustable anti-vibration cones reduces the contact surface, limiting vibration transfer and enabling controlled energy dissipation.

Filling the legs with quartz sand increases the system's inertia and introduces additional internal damping. The granular material acts as a mechanical filter, effectively dispersing higher-frequency vibrations and limiting their propagation within the structure.

Each rack is delivered with a factory-optimized ballast filling, ensuring proper operating conditions. At the same time, the design allows for further tuning – threaded openings in the legs enable adjustment of the amount or type of ballast, allowing users to fine-tune the performance.

### Sound performance

In practice, this results in a more natural and stable sound presentation, improved low-frequency control, and greater precision in imaging and instrument separation.

### CUSTOM CONFIGURATION

Custom configurations are available upon request – including the number of levels and overall dimensions. Each unit can be precisely tailored to match a specific audio system and its operating conditions.



modification according to individual requests  
size change, kind of frame,  
kind of shelves, kind of decoupling



SYSTEM



<https://www.rogoz-audio.com>  
[office@rogoz-audio.com](mailto:office@rogoz-audio.com)  
[januszrogoz@yahoo.pl](mailto:januszrogoz@yahoo.pl)

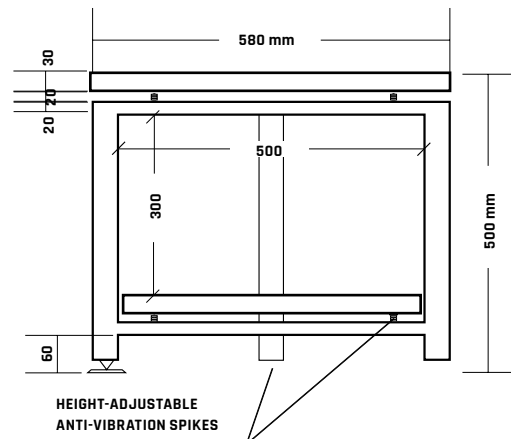
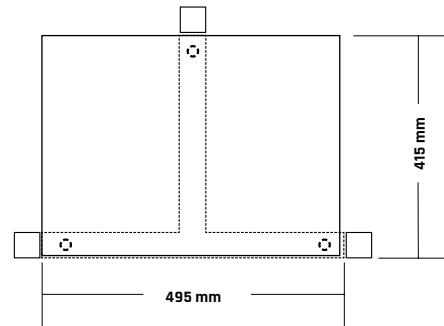
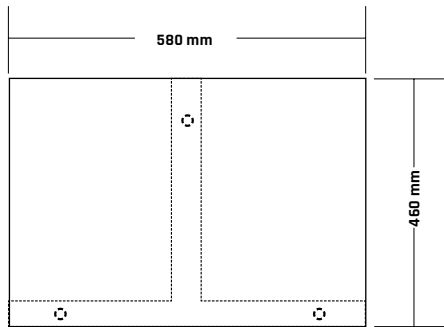

VIEW FROM ABOVE  
top shelf center shelf

FRONT VIEW

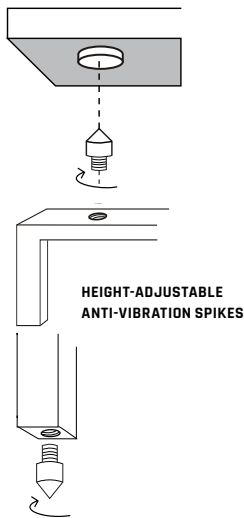

### TECHNICAL DESCRIPTION

- Overall height: 500 mm;
- Overall width: 580 mm;
- Overall depth: 460 mm;
- Leg profile: 40 x 40 mm;
- Top shelf: 580 x 460 x 30 mm;
- Bottom shelf: 495 x 415 x 30 mm;
- Usable distance between the shelves: 300 mm;
- Maximum load for each shelf: up to 50 kg (total: 100 kg)

2-level, three-legged stand with sandwich structure shelves. The shelves color: verde chiaro (glossy). The frame color: verde chiaro (semi-matte).

Anti-vibration stands are designed for high end audio components. The frame has been tuned by a suitable combination of alloy steel and high-fiber content steel. The frame consist of extra-strong legs made of carbon steel S235JR (which is used for load-bearing stuctures subject to heavy dynamic load, e.g. in cranes) connected by crosspieces made from higher-strength alloy steel S355. Adjustable anti-vibration spikes are used for for high-precision leveling.

### A COMPLETE SET INCLUDES

- 1 steel frame;
- 2 shelves (MDF/HDF/MDF SANDWICH STRUCTURE);
- 9 height-adjustable spikes;
- 6 anti-vibration separating disks;
- 3 anti-scratch disks protecting the floor

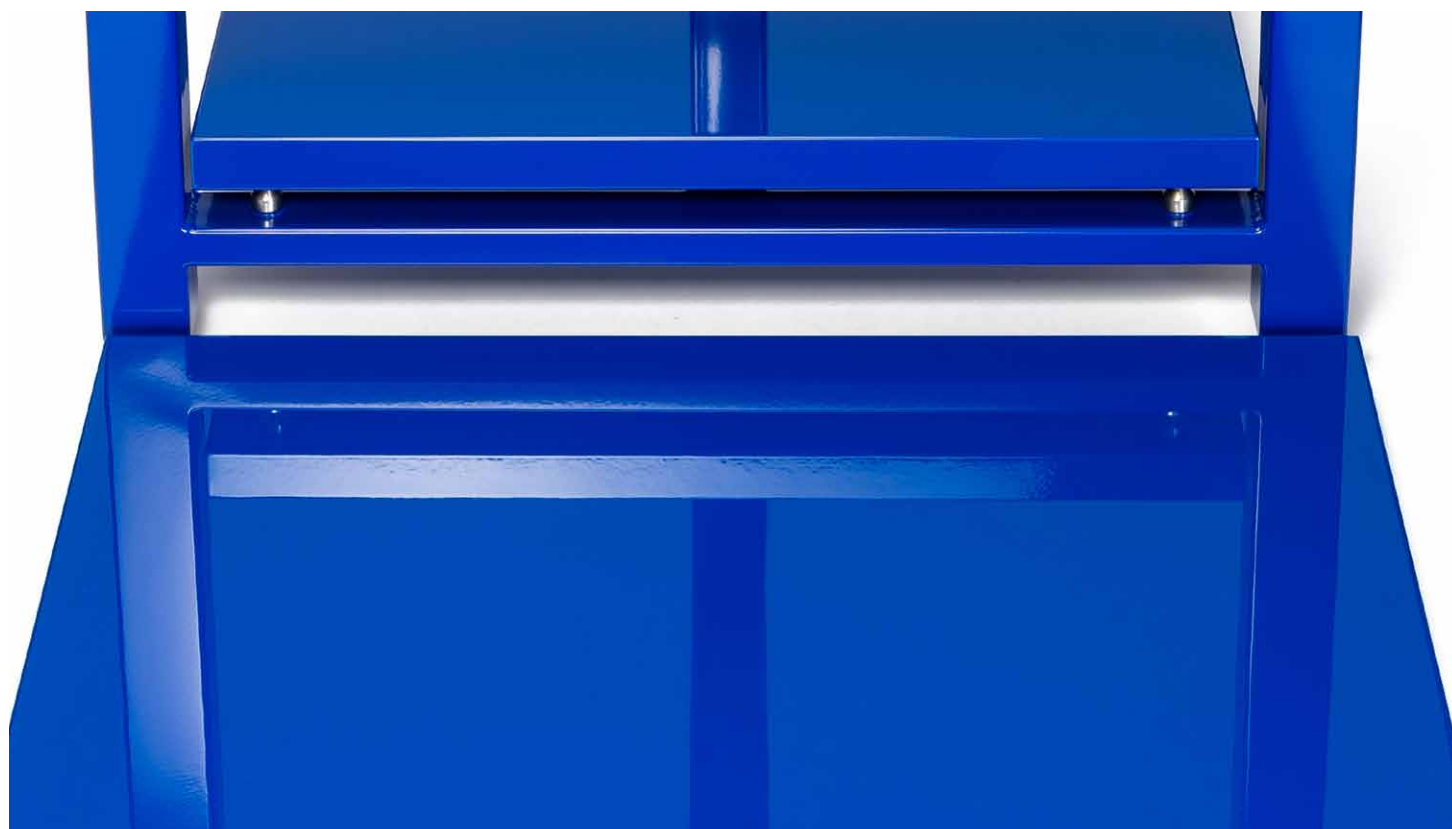

modification according to individual requests  
size change, kind of frame,  
kind of shelves, kind of decoupling



<https://www.rogoz-audio.com>  
[office@rogoz-audio.com](mailto:office@rogoz-audio.com)  
[januszrogoz@yahoo.pl](mailto:januszrogoz@yahoo.pl)

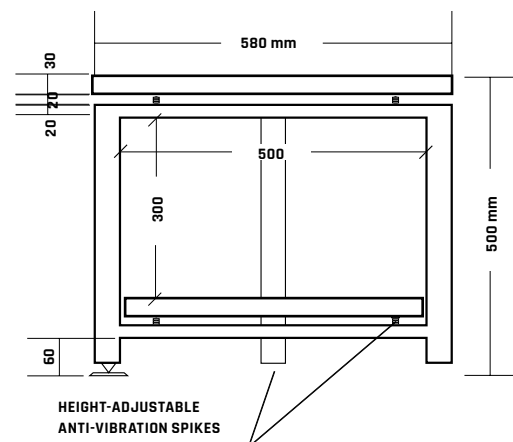
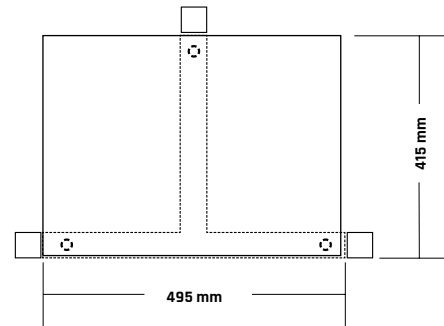
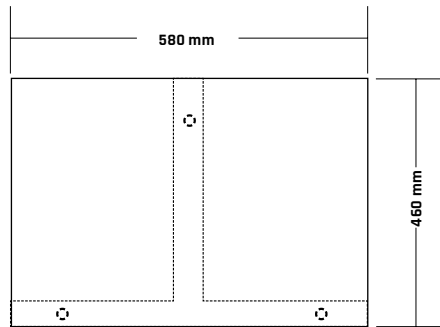

VIEW FROM ABOVE  
top shelf center shelf

FRONT VIEW

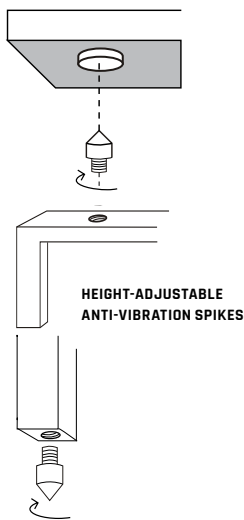

### TECHNICAL DESCRIPTION

- Overall height: 500 mm;
- Overall width: 580 mm;
- Overall depth: 460 mm;
- Leg profile: 40 x 40 mm;
- Top shelf: 580 x 460 x 30 mm;
- Bottom shelf: 495 x 415 x 30 mm;
- Usable distance between the shelves: 300 mm;
- Maximum load for each shelf: up to 50 kg (total: 100 kg)

2-level, three-legged stand with sandwich structure shelves. The shelves color: marin (glossy). The frame color: marin (semi-matte).

Anti-vibration stands are designed for high end audio components. The frame has been tuned by a suitable combination of alloy steel and high-fiber content steel. The frame consist of extra-strong legs made of carbon steel S235JR (which is used for load-bearing structures subject to heavy dynamic load, e.g. in cranes) connected by crosspieces made from higher-strength alloy steel S355. Adjustable anti-vibration spikes are used for for high-precision leveling.

### A COMPLETE SET INCLUDES

- 1 steel frame;
- 2 shelves (MDF/HDF/MDF SANDWICH STRUCTURE);
- 9 height-adjustable spikes;
- 6 anti-vibration separating disks;
- 3 anti-scratch disks protecting the floor



modification according to individual requests  
size change, kind of frame,  
kind of shelves, kind of decoupling



<https://www.rogoz-audio.com>  
[office@rogoz-audio.com](mailto:office@rogoz-audio.com)  
[januszrogoz@yahoo.pl](mailto:januszrogoz@yahoo.pl)

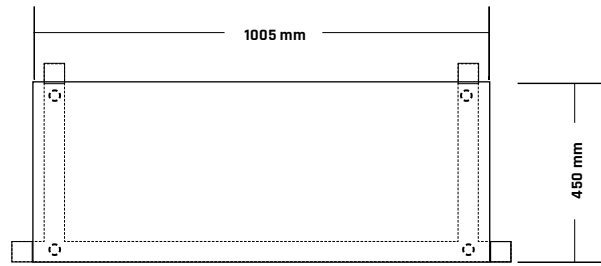
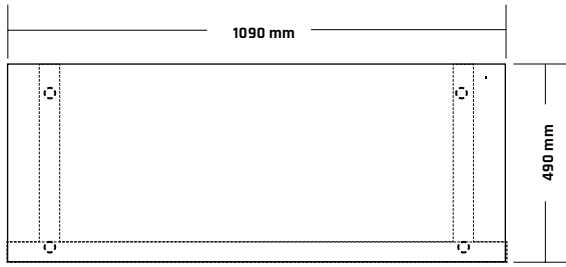

VIEW FROM ABOVE  
top shelf center shelf

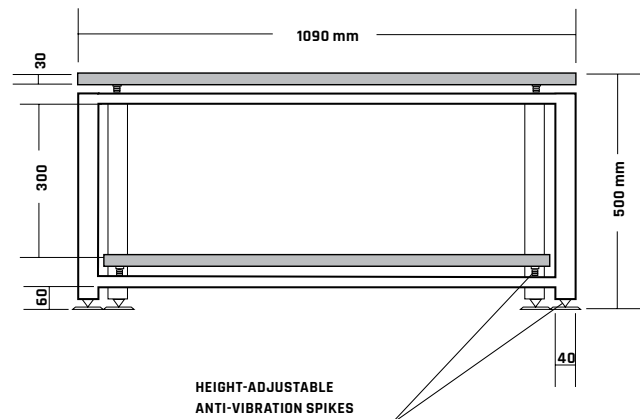
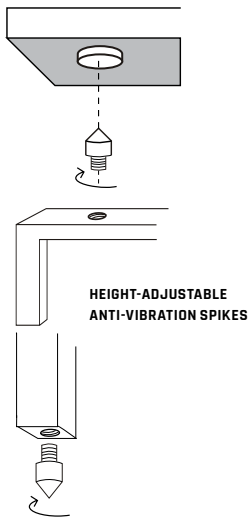

FRONT VIEW

### TECHNICAL DESCRIPTION

- Overall height: 500 mm;
- Overall width: 1090 mm;
- Overall depth: 490 mm;
- Leg profile: 40 x 40 mm;
- Top shelf: 1090 x 490 x 30 mm;
- Bottom shelf: 1005 x 450 x 30 mm;
- Usable distance between the shelves (moving upwards): 300 mm;
- Maximum load for each shelf: up to 100 kg (total: 200 kg), with an evenly distributed load across the entire width of the shelves.

### A COMPLETE SET INCLUDES

- 1 steel frame;
- 2 shelves (MDF/HDF/MDF/ SANDWICH STRUCTURE);
- 12 height-adjustable spikes;
- 8 anti-vibration separating disks;
- 4 anti-scratch disks protecting the floor

2-level, four-legged stand with sandwich structure shelves. The shelves color: black (matte). The frame color: black (matte, fine grain).

Anti-vibration stands are designed for high end audio components. The frame has been tuned by a suitable combination of alloy steel and high-fiber content steel. The frame consist of extra-strong legs made of carbon steel S235JR (which is used for load-bearing stuctures subject to heavy dynamic load, e.g. in cranes) connected by crosspieces made from higher-strength alloy steel S355. Adjustable anti-vibration spikes are used for for high-precision leveling.

80 kg

 including the packaging and pallet



modification according to individual requests  
size change, kind of frame,  
kind of shelves, kind of decoupling



<https://www.rogoz-audio.com>  
[office@rogoz-audio.com](mailto:office@rogoz-audio.com)  
[januszrogoz@yahoo.pl](mailto:januszrogoz@yahoo.pl)

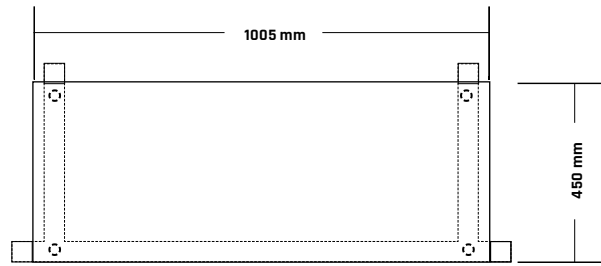
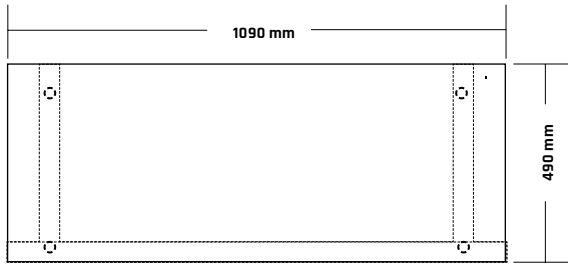

VIEW FROM ABOVE  
top shelf center shelf

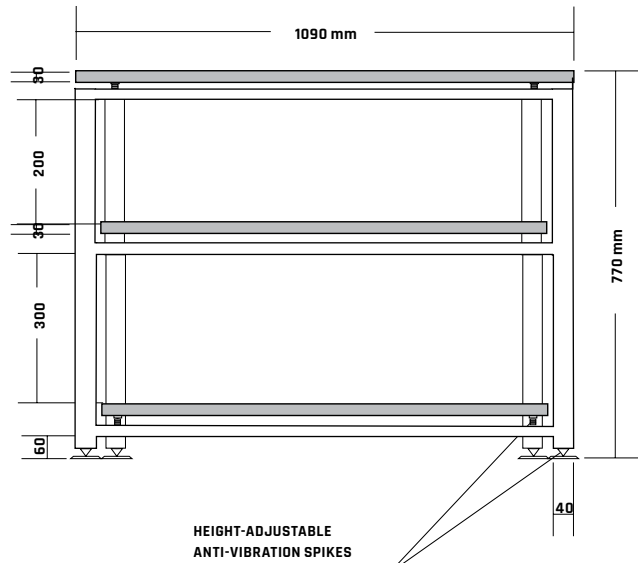
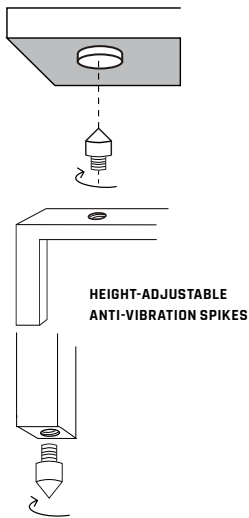

FRONT VIEW

### TECHNICAL DESCRIPTION

- Overall height: 770 mm;
- Overall width: 1090 mm;
- Overall depth: 490 mm;
- Leg profile: 40 x 40 mm;
- Top shelf: 1090 x 490 x 30 mm;
- Middle and bottom shelves: 1005 x 450 x 30 mm;
- Usable distance between the shelves (moving upwards): 300, 200 mm;
- Maximum load for each shelf: up to 100 kg (total: 300 kg), with an evenly distributed load across the entire width of the shelves.

3-level, four-legged stand with sandwich structure shelves. The shelves color: black (matte). The frame color: black (matte, fine grain).

Anti-vibration stands are designed for high end audio components. The frame has been tuned by a suitable combination of alloy steel and high-fiber content steel. The frame consist of extra-strong legs made of carbon steel S235JR (which is used for load-bearing stuctures subject to heavy dynamic load, e.g. in cranes) connected by crosspieces made from higher-strength alloy steel S355. Adjustable anti-vibration spikes are used for for high-precision leveling.

### A COMPLETE SET INCLUDES

- 1 steel frame;
- 3 shelves (MDF/HDF/MDF/ SANDWICH STRUCTURE);
- 16 height-adjustable spikes;
- 12 anti-vibration separating disks;
- 4 anti-scratch disks protecting the floor

100 kg



including  
the packaging  
and pallet



modification according to individual requests  
size change, kind of frame,  
kind of shelves, kind of decoupling



<https://www.rogoz-audio.com>  
[office@rogoz-audio.com](mailto:office@rogoz-audio.com)  
[januszrogoz@yahoo.pl](mailto:januszrogoz@yahoo.pl)

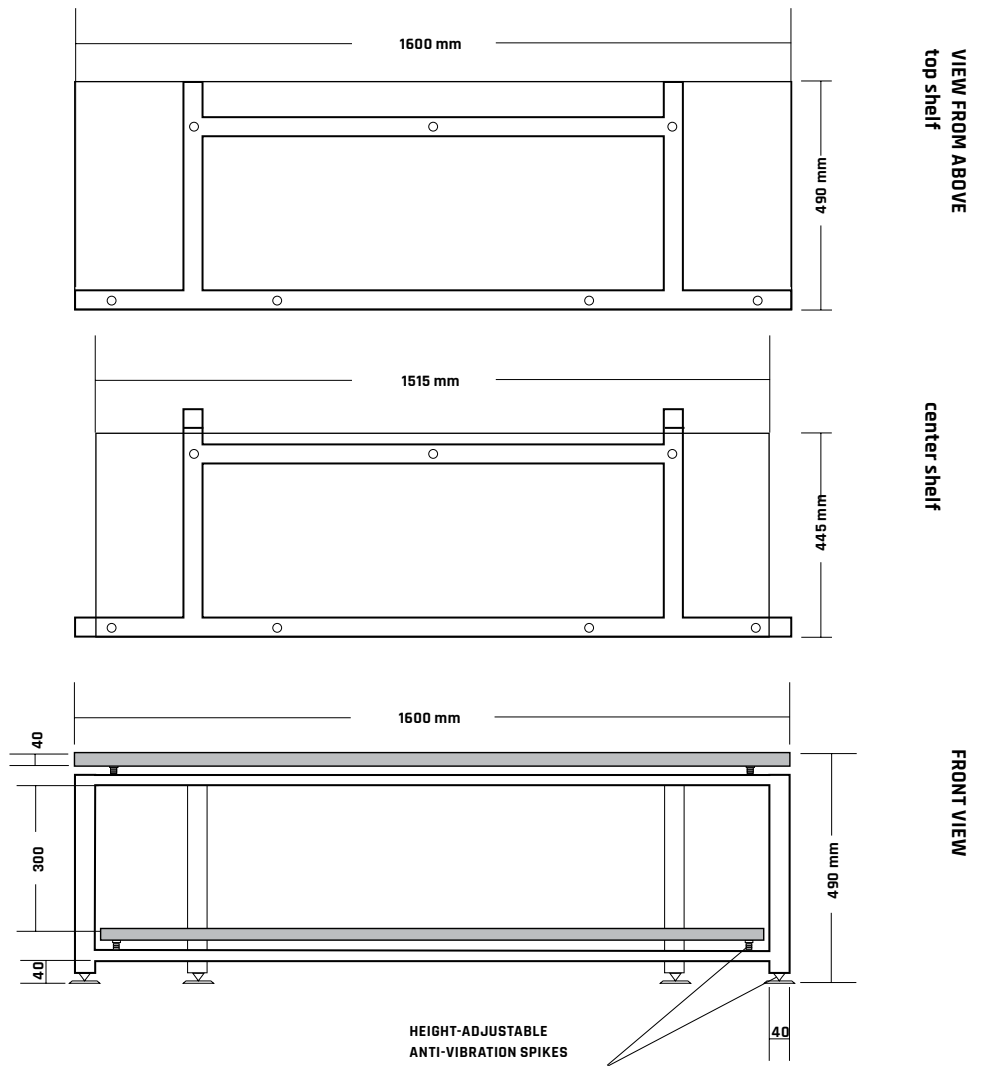
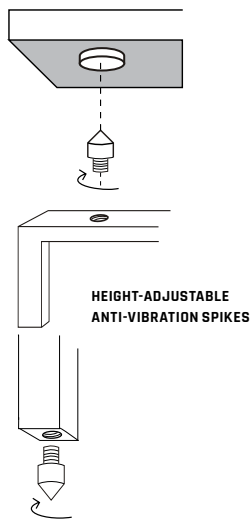

### TECHNICAL DESCRIPTION

- Overall height: 490 mm;
- Overall width: 1600 mm;
- Overall depth: 490 mm;
- Leg profile: 40 x 40 mm;
- Top shelf: 1600 x 490 x 40 mm;
- Bottom shelf: 1515 x 445 x 30 mm;
- Usable distance between the shelves (moving upwards): 300 mm;
- Maximum load for each shelf: up to 100 kg (total: 200 kg), with an evenly distributed load across the entire width of the shelves.

### A COMPLETE SET INCLUDES

- 1 steel frame;
- 2 shelves (MDF/HDF/MDF/ SANDWICH STRUCTURE);
- 18 height-adjustable spikes;
- 14 anti-vibration separating disks;
- 4 anti-scratch disks protecting the floor

2-level, four-legged stand with sandwich structure shelves. The shelves color: black (matte). The frame color: black (matte, fine grain).

Anti-vibration stands are designed for high end audio components. The frame has been tuned by a suitable combination of alloy steel and high-fiber content steel. The frame consist of extra-strong legs made of carbon steel S235JR (which is used for load-bearing stuctures subject to heavy dynamic load, e.g. in cranes) connected by crosspieces made from higher-strength alloy steel S355. Adjustable anti-vibration spikes are used for for high-precision leveling.

90 kg

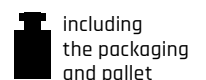



modification according to individual requests  
size change, kind of frame,  
kind of shelves, kind of decoupling



<https://www.rogoz-audio.com>  
[office@rogoz-audio.com](mailto:office@rogoz-audio.com)  
[januszrogoz@yahoo.pl](mailto:januszrogoz@yahoo.pl)

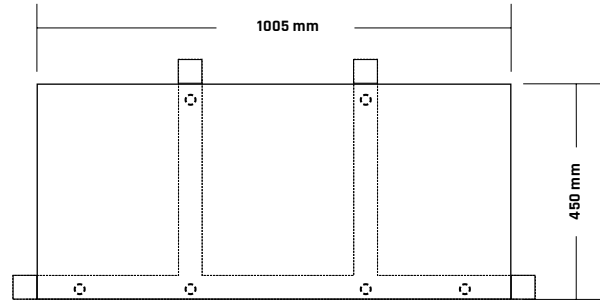
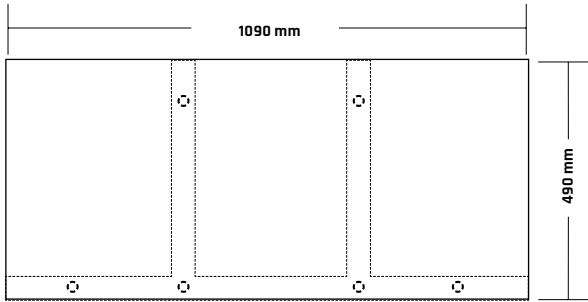

VIEW FROM ABOVE  
top shelf center shelf

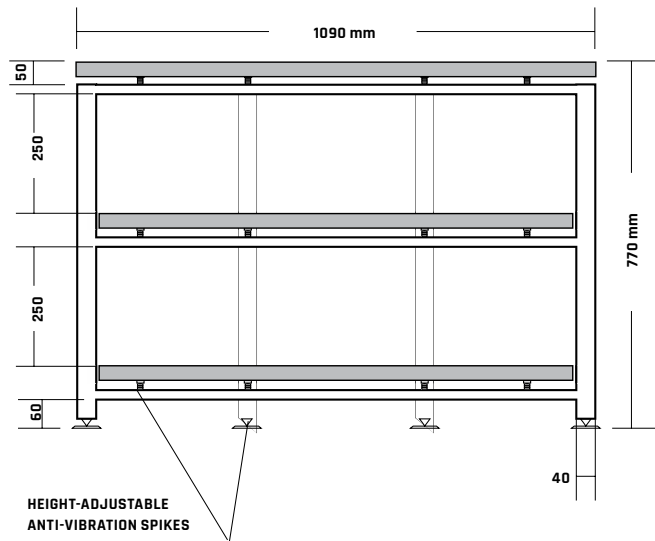
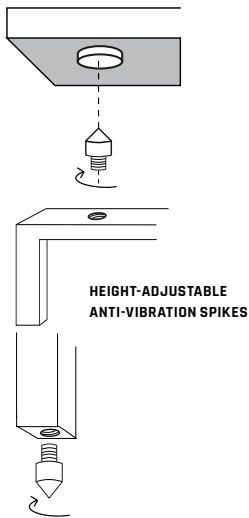

FRONT VIEW

### TECHNICAL DESCRIPTION

- Overall height: 770 mm
- Overall width: 1090 mm
- Overall depth: 490 mm
- Leg profile: 40 x 40 mm
- Top shelf: 1090 x 490 x 30 mm
- Middle and bottom shelves: 1005 x 450 x 30 mm
- Usable distance between the shelves (moving upwards): 250, 250 mm
- Maximum load for each shelf: up to 100 kg (total: 300 kg)

3-level, four-legged stand with 30 mm thick shelves covered in natural wood veneer (american walnut). The frame color: golden brass (glossy).

Anti-vibration stands are designed for high end audio components. The frame has been tuned by a suitable combination of alloy steel and high-fiber content steel. The frame consist of extra-strong legs made of carbon steel S235JR (which is used for load-bearing stuctures subject to heavy dynamic load, e.g. in cranes) connected by crosspieces made from higher-strength alloy steel S355. Adjustable anti-vibration spikes are used for for high-precision leveling.

### A COMPLETE SET INCLUDES

- 1 steel frame
- 3 shelves (MDF/HDF/MDF/wood veneer - sandwich structure)
- 22 height-adjustable spikes
- 18 anti-vibration separating disks
- 4 anti-scratch disks protecting the floor

90 kg

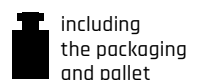



modification according to individual requests  
size change, kind of frame,  
kind of shelves, kind of decoupling



<https://www.rogoz-audio.com>  
[office@rogoz-audio.com](mailto:office@rogoz-audio.com)  
[januszrogoz@yahoo.pl](mailto:januszrogoz@yahoo.pl)

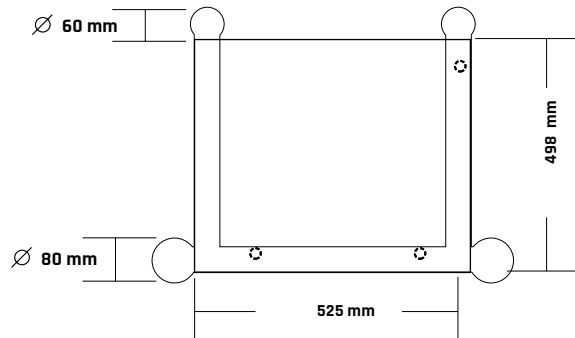
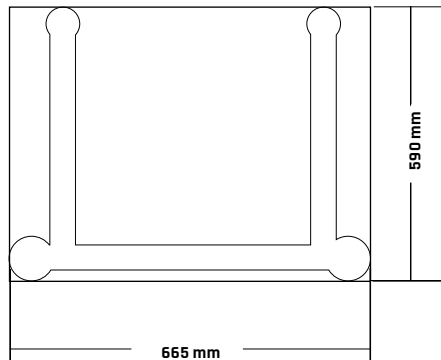

VIEW FROM ABOVE  
top shelf center shelf

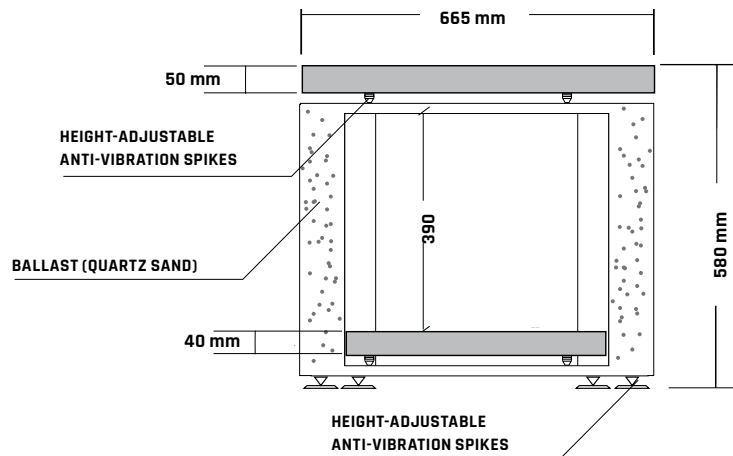
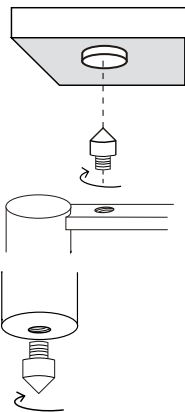

FRONT VIEW

### TECHNICAL DESCRIPTION

- Overall height: 580 mm;
- Overall width: 665 mm;
- Overall depth: 590 mm;
- Leg profile: steel pipes (80 mm - front, 60 mm - back);
- Top shelf: 665 x 590 x 50 mm;
- Bottom shelves: 498x 525 x 40 mm;
- Usable distance between the shelves: 390 mm;
- Maximum load for each shelf: up to 150 kg (total: 300 kg);
- Ballast: quartz sand

### A COMPLETE SET INCLUDES

- 1 steel frame;
- 2 shelves (MDF/HDF/MDF/wood veneer - sandwich structure);
- 12 height-adjustable spikes;
- 8 anti-vibration separating disks;
- 4 massive anti-scratch disks protecting the floor

2-level, four-legged stand, with shelves covered in natural wood veneer (american walnut). The top shelf is optimal for analog gramophones and digital signal sources. The frame contains quartz sand ballast (bolted holes in the legs make it possible to change the amount and kind of ballast). The frame color: black (matt, fine grain). Anti-vibration stands are designed for high end audio components. The frame has been tuned by a suitable combination of alloy steel and high-fiber content steel. The frame consist of extra-strong legs made of carbon steel S235JR (which is used for load-bearing stuctures subject to heavy dynamic load, e.g. in cranes) connected by crosspieces made from higher-strength alloy steel S355. Adjustable anti-vibration spikes are used for for high-precision leveling.

80 kg

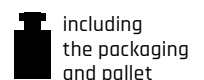



modification according to individual requests  
size change, kind of frame,  
kind of shelves, kind of decoupling



<https://www.rogoz-audio.com>  
[office@rogoz-audio.com](mailto:office@rogoz-audio.com)  
[januszrogoz@yahoo.pl](mailto:januszrogoz@yahoo.pl)

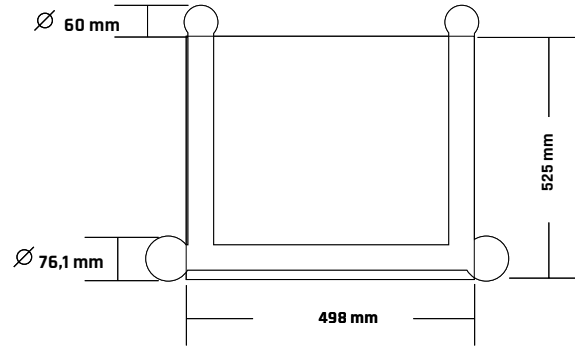
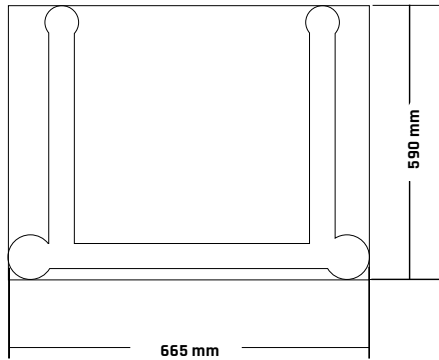

VIEW FROM ABOVE  
top shelf center shelf

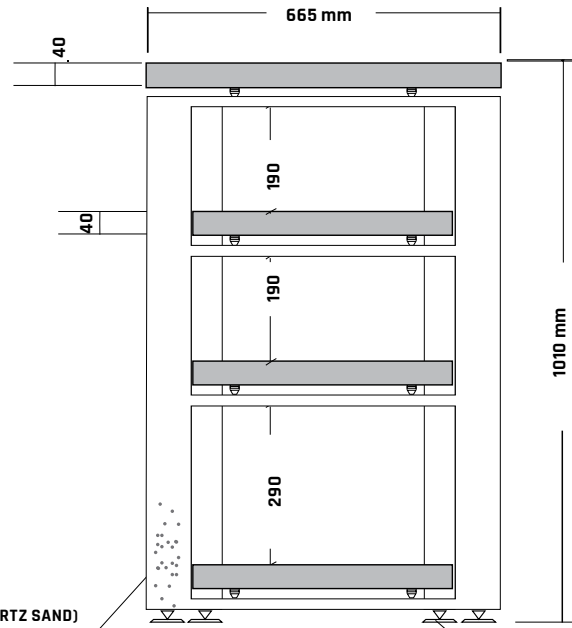
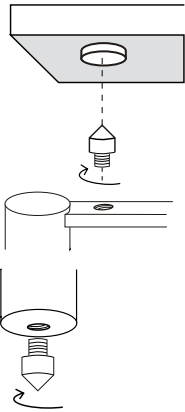

FRONT VIEW

BALLAST (QUARTZ SAND)

HEIGHT-ADJUSTABLE  
ANTI-VIBRATION SPIKES

### TECHNICAL DESCRIPTION

- Overall height: 1010 mm;
- Overall width: 665 mm;
- Overall depth: 590 mm;
- Leg profile: steel pipes (80 mm - front, 60 mm - back);
- Top shelf: 665 x 590 x 40 mm;
- Bottom shelves: 498 x 525 x 40 mm;
- Usable distance between the shelves (moving upwards): 290, 190, 190 mm;

4-level, four-legged stand, with sandwich structure shelves. The shelves color: black (matte). The frame color: black (matte, fine grain). The frame contains quartz sand ballast (bolted holes in the legs make it possible to change the amount and kind of ballast).

Anti-vibration stands are designed for high end audio components. The frame has been tuned by a suitable combination of alloy steel and high-fiber content steel. The frame consist of extra-strong legs made of carbon steel S235JR (which is used for load-bearing stuctures subject to heavy dynamic load, e.g. in cranes) connected by crosspieces made from higher-strength alloy steel S355. Adjustable anti-vibration spikes are used for for high-precision leveling.

### A COMPLETE SET INCLUDES

- 1 steel frame
- 4 shelves (MDF/HDF/MDF/ SANDWICH STRUCTURE);
- 20 height-adjustable spikes
- 16 anti-vibration separating disks
- 4 massive anti-scratch disks protecting the floor

120 kg

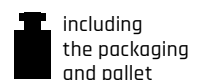

including  
the packaging  
and pallet



modification according to individual requests  
size change, kind of frame,  
kind of shelves, kind of decoupling



<https://www.rogoz-audio.com>  
[office@rogoz-audio.com](mailto:office@rogoz-audio.com)  
[januszrogoz@yahoo.pl](mailto:januszrogoz@yahoo.pl)

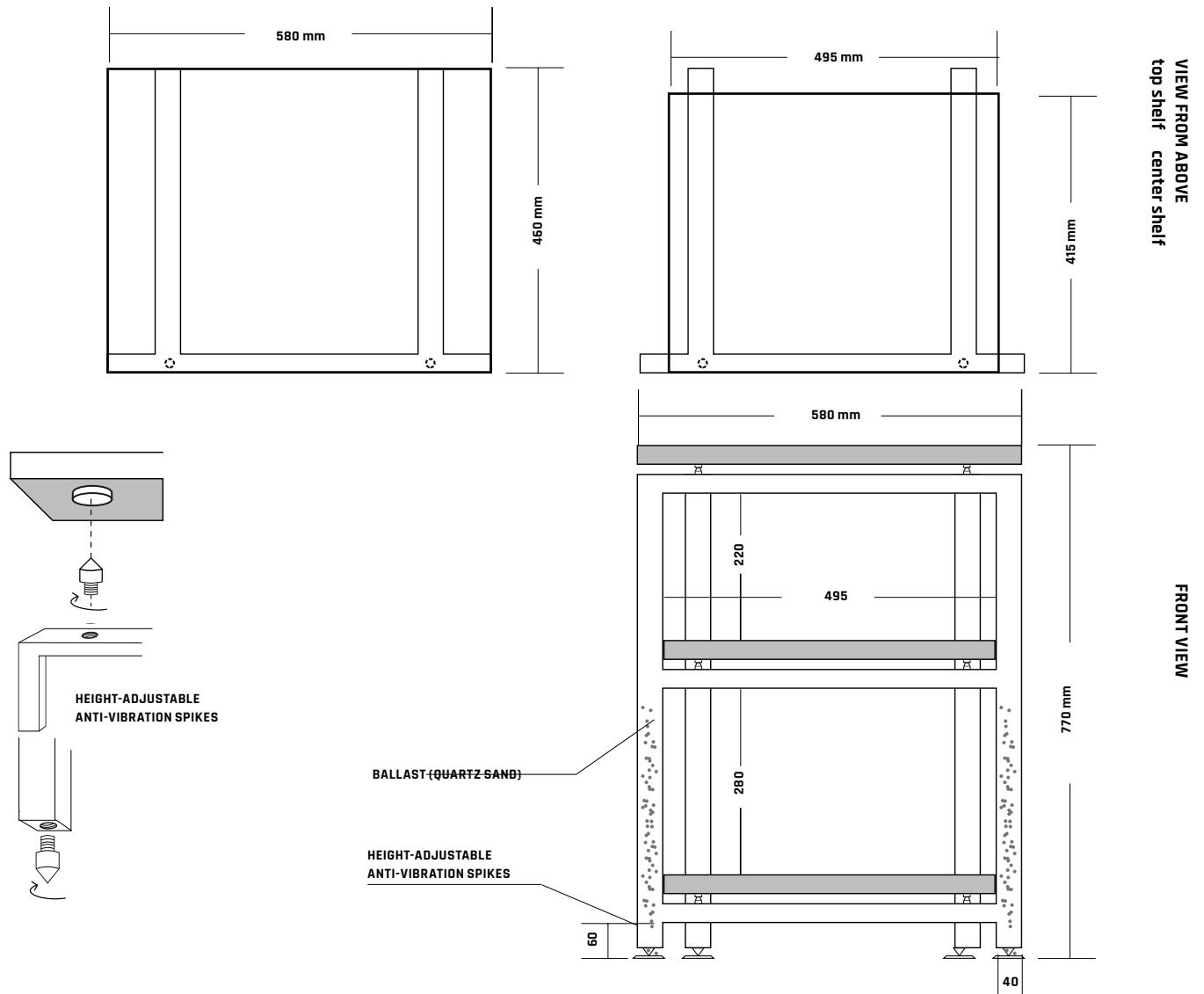

### TECHNICAL DESCRIPTION

- Overall height: 770 mm;
- Overall width: 580 mm;
- Overall depth: 460 mm;
- Leg profile: 40 x 40 mm;
- Top shelf: 580 x 460 x 30 mm;
- Middle and bottom shelves: 495 x 415 x 30 mm;
- Usable distance between the shelves (moving upwards): 280, 220 mm;
- Maximum load for each shelf: up to 100 kg (total: 300 kg)

### A COMPLETE SET INCLUDES

- 1 steel frame;
- 3 shelves (MDF/HDF/MDF SANDWICH STRUCTURE);
- 16 height-adjustable spikes;
- 12 anti-vibration separating disks;
- 4 anti-scratch disks protecting the floor

3-level, four-legged stand with sandwich structure shelves. The shelves color: verde chiaro (glossy). The frame color: verde chiaro (semi-matte).

Anti-vibration stands are designed for high end audio components. The frame has been tuned by a suitable combination of alloy steel and high-fiber content steel. The frame consist of extra-strong legs made of carbon steel S235JR (which is used for load-bearing stuctures subject to heavy dynamic load, e.g. in cranes) connected by crosspieces made from higher-strength alloy steel S355. Adjustable anti-vibration spikes are used for for high-precision leveling.



modification according to individual requests  
size change, kind of frame,  
kind of shelves, kind of decoupling



<https://www.rogoz-audio.com>  
office@rogoz-audio.com  
januszrogoz@yahoo.pl

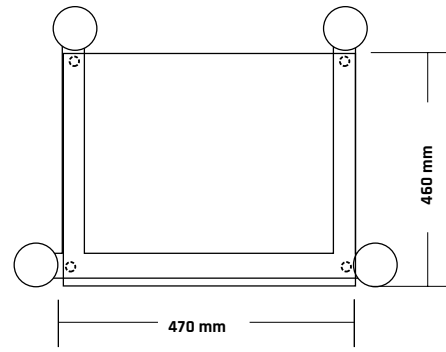
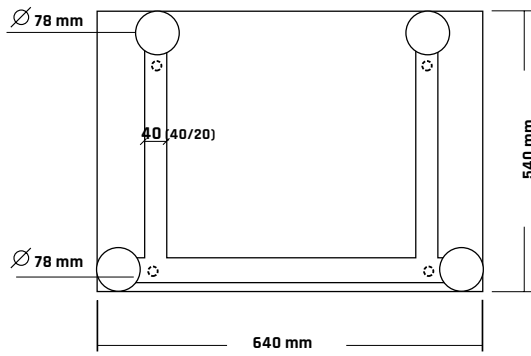

VIEW FROM ABOVE  
top shelf center shelf

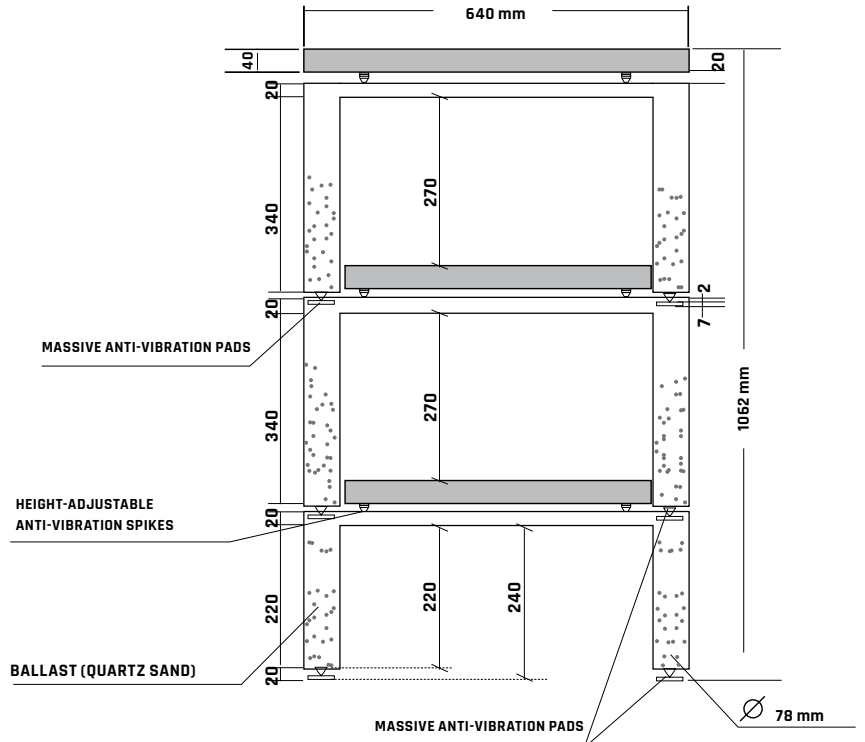
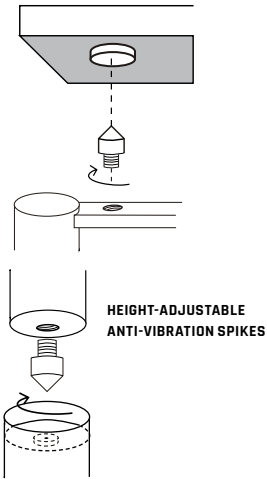

FRONT VIEW

### TECHNICAL DESCRIPTION

- Maximum height (vertical): 1062 mm
- Overall width: 640 mm
- Overall depth: 540 mm
- Leg profile: steel pipes (Ø 76 mm - front/back)
- Top shelf: 640 x 540 x 40 mm
- Lower shelves: 470 x 460 x 40 mm
- Usable distance between the shelves (moving upwards): 270, 270 mm (the order of modules may be changed)
- Maximum load for each shelf: up to 80 kg (total: 240 kg)
- Ballast: quartz sand

3-level, four-legged stand with shelves covered in natural wood veneer (venge). The frame color is black (matt, fine grain). The structure consists of individual modules, which can be placed vertically (one on top of another) or side by side. The modules are separated by means of height-adjustable spikes and anti-vibration pads. The original set may be expanded by adding extra modules.

Anti-vibration stands are designed for high end audio components. The frame has been tuned by a suitable combination of alloy steel and high-fiber content steel. The frame consist of extra-strong legs made of carbon steel S235JR (which is used for load-bearing structures subject to heavy dynamic load, e.g. in cranes) connected by crosspieces made from higher-strength alloy steel S355. Adjustable anti-vibration spikes are used for high-precision leveling.

### A COMPLETE SET INCLUDES

- 3 steel frames
- 3 shelves (MDF/HDF/MDF/wood veneer - sandwich structure)
- 24 height-adjustable spikes
- 12 massive separating pads

110 kg

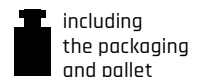



modification according to individual requests  
size change, kind of frame,  
kind of shelves, kind of decoupling



<https://www.rogoz-audio.com>  
[office@rogoz-audio.com](mailto:office@rogoz-audio.com)  
[januszrogoz@yahoo.pl](mailto:januszrogoz@yahoo.pl)

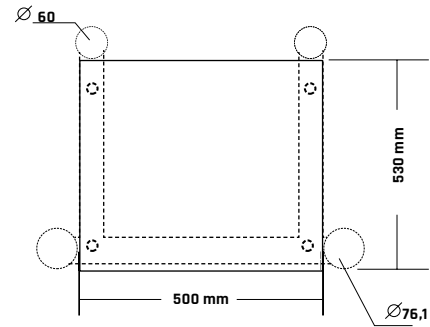
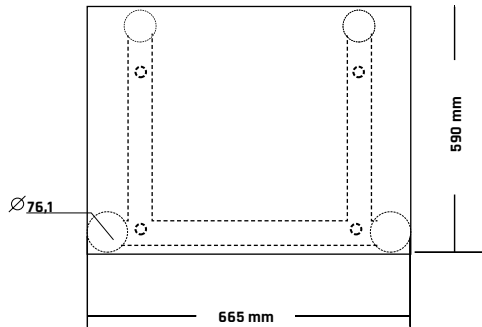

VIEW FROM ABOVE  
top shelf center shelf

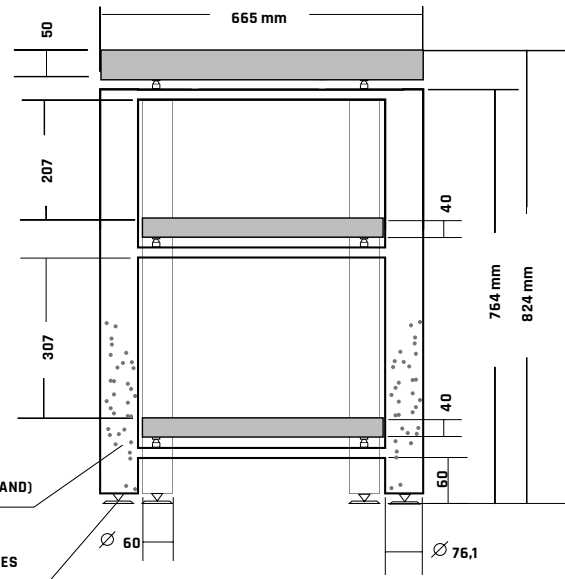
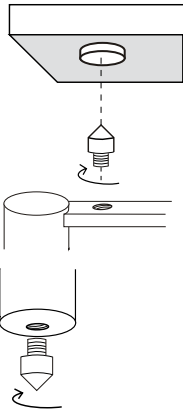

FRONT VIEW

### TECHNICAL DESCRIPTION

- Overall height: 824 mm
- Overall width: 665 mm
- Overall depth: 590 mm
- Leg profile: steel pipes (Ø 76.1 mm – front, Ø 60 mm – back)
- Top shelf: 665 x 590 x 50 mm
- Center and bottom shelves: 500 x 530 x 40 mm
- Usable distance between the shelves (moving upwards): 307, 207 mm
- Maximum load for each shelf: up to 150 kg (total: 450 kg)
- Ballast: quartz sand

3-level, four-legged stand with shelves covered in natural wood veneer (merbau). The top shelf is optimal for analog gramophones and digital signal sources.

The frame contains quartz sand ballast (bolted holes in the legs make it possible to change the amount and kind of ballast). The frame color: black (matt, fine grain).

Anti-vibration stands are designed for high end audio components. The frame has been tuned by a suitable combination of alloy steel and high-fiber content steel. The frame consist of extra-strong legs made of carbon steel S235JR (which is used for load-bearing stuctures subject to heavy dynamic load, e.g. in cranes) connected by crosspieces made from higher-strength alloy steel S355. Adjustable anti-vibration spikes are used for high-precision leveling.

### A COMPLETE SET INCLUDES

- 1 steel frame
- 3 shelves (MDF/HDF/MDF/wood veneer - sandwich structure)
- 16 height-adjustable spikes
- 4 massive anti-scratch disks protecting the floor

100 kg

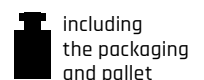



modification according to individual requests  
size change, kind of frame,  
kind of shelves, kind of decoupling



<https://www.rogoz-audio.com>  
[office@rogoz-audio.com](mailto:office@rogoz-audio.com)  
[januszrogoz@yahoo.pl](mailto:januszrogoz@yahoo.pl)

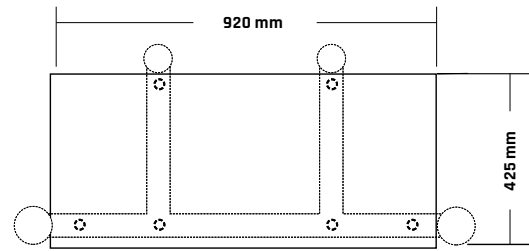
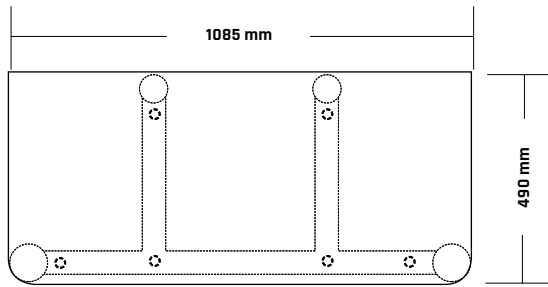

VIEW FROM ABOVE  
top shelf center shelf

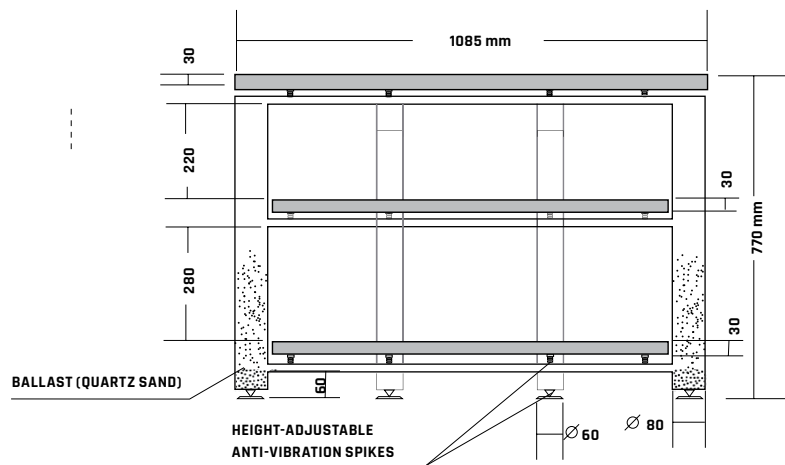
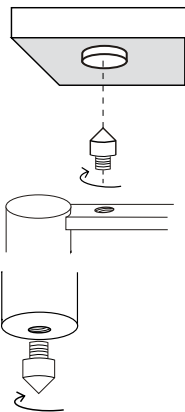

FRONT VIEW

### TECHNICAL DESCRIPTION

- Total height: 770 mm;
- Overall width: 1085 mm;
- Overall depth: 490 mm;
- Leg profiles: steel pipes (Ø 80 mm - front, Ø 60 mm - back);
- Top shelf: 1085 x 490 x 30 mm;
- Middle and bottom shelves: 920 x 425 x 30 mm;
- Usable distance between the shelves (moving upwards): 280, 220 mm;
- Maximum load for each shelf: up to 150 kg (total: 450 kg);
- Ballast: quartz sand

### A COMPLETE SET INCLUDES

- 1 steel frame;
- 3 shelves (MDF/HDF/MDF - sandwich structure);
- 22 height-adjustable spikes;
- 18 soft anti-vibration pads;
- 4 massive anti-scratch disks protecting the floor

3-level, four-legged stand with glossy piano black finish shelves. The frame contains quartz sand ballast (bolted holes in the legs make it possible to change the amount and kind of ballast). The frame color: black (glossy).

Anti-vibration stands are designed for high end audio components. The frame has been tuned by a suitable combination of alloy steel and high-fiber content steel. The frame consist of extra-strong legs made of carbon steel S235JR (which is used for load-bearing structures subject to heavy dynamic load, e.g. in cranes) connected by crosspieces made from higher-strength alloy steel S355. Adjustable anti-vibration spikes are used for high-precision leveling.

130 kg

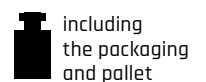



modification according to individual requests  
size change, kind of frame,  
kind of shelves, kind of decoupling



<https://www.rogoz-audio.com>  
[office@rogoz-audio.com](mailto:office@rogoz-audio.com)  
[januszrogoz@yahoo.pl](mailto:januszrogoz@yahoo.pl)

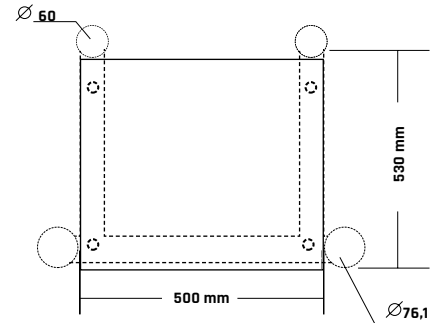
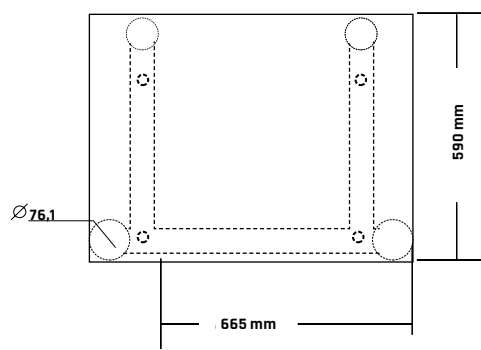

VIEW FROM ABOVE  
top shelf center shelf

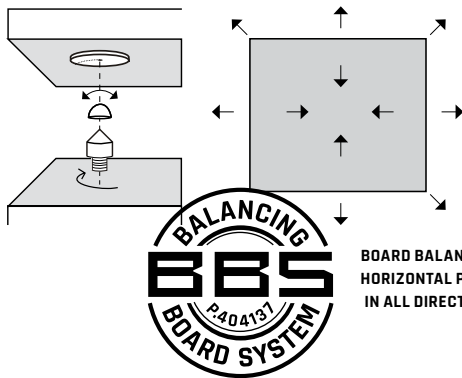

BOARD BALANCING INVOLVES  
HORIZONTAL PLANE MOVEMENT  
IN ALL DIRECTIONS

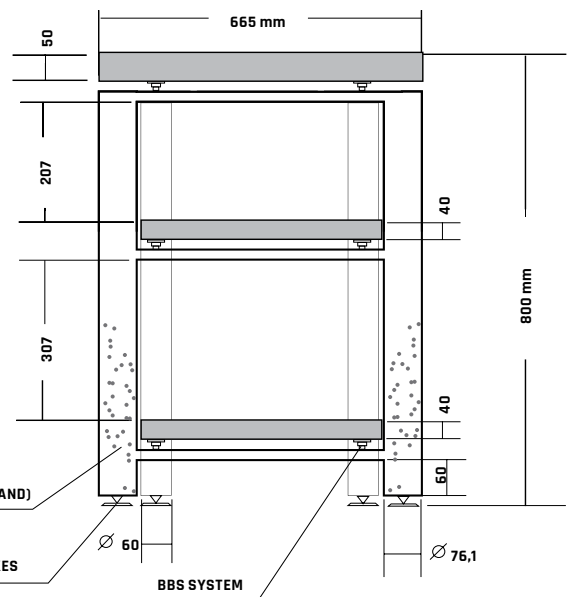

FRONT VIEW

BALLAST (QUARTZ SAND)

HEIGHT-ADJUSTABLE  
ANTI-VIBRATION SPIKES

BBS SYSTEM

### TECHNICAL DESCRIPTION

- Overall height: 800 mm
- Overall width: 665 mm
- Overall depth: 590 mm
- Leg profile: steel pipes (Ø 76.1 mm - front, Ø 60 mm - back)
- Top shelf: 665 x 590 x 50 mm
- Center and bottom shelves: 500 x 530 x 40 mm
- Usable distance between the shelves (moving upwards): 307, 207 mm
- Maximum load for each shelf: up to 150 kg (total: 450 kg)
- Ballast: quartz sand

### A COMPLETE SET INCLUDES

- 1 steel frame
- 3 shelves (MDF/HDF/MDF/ - sandwich structure)
- 4 height-adjustable spikes
- BBS under each shelf
- 4 massive anti-scratch disks protecting the floor

3-level, four-legged stand with glossy piano black finish shelves. The frame contains quartz sand ballast (bolted holes in the legs make it possible to change the amount and kind of ballast). The frame color: piano black (glossy). The top shelf is 50 mm thick with sandwich structure and is optimal for analog gramophones and digital signal sources. The middle and bottom shelves are 40 mm thick and have a similar structure. All the shelves are separated from the stand frame by the Balancing Board System. BBS has kinematic and dynamic qualities which enable isolated masses to "float" to the sides relative to the system axis, maintaining point support at the same time. BBS also makes it possible to level the stand shelves.

Anti-vibration stands are designed for high end audio components. The frame has been tuned by a suitable combination of alloy steel and high-fiber content steel. The frame consist of extra-strong legs made of carbon steel S235JR (which is used for load-bearing stuctures subject to heavy dynamic load, e.g. in cranes) connected by crosspieces made from higher-strength alloy steel S355. Adjustable anti-vibration spikes are used for high-precision leveling.

100 kg

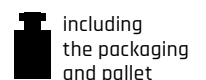



modification according to individual requests  
size change, kind of frame,  
kind of shelves, kind of decoupling



<https://www.rogoz-audio.com>  
[office@rogoz-audio.com](mailto:office@rogoz-audio.com)  
[januszrogoz@yahoo.pl](mailto:januszrogoz@yahoo.pl)

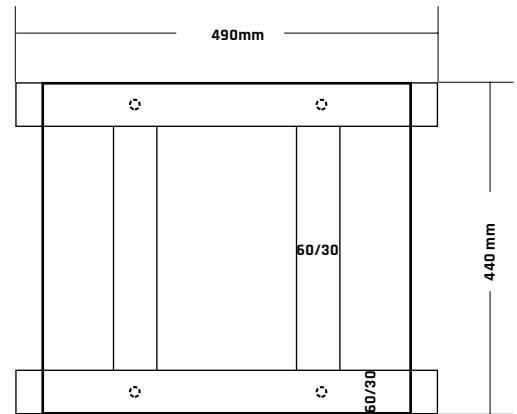
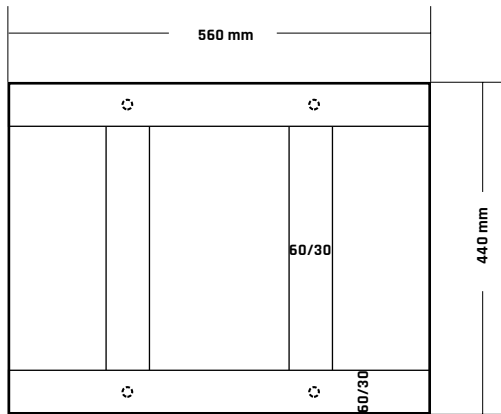

VIEW FROM ABOVE  
top shelf center shelf

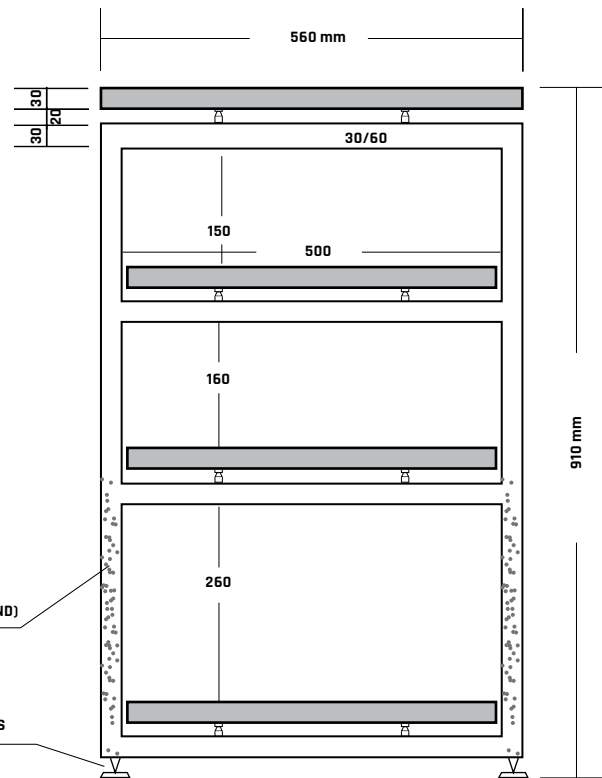
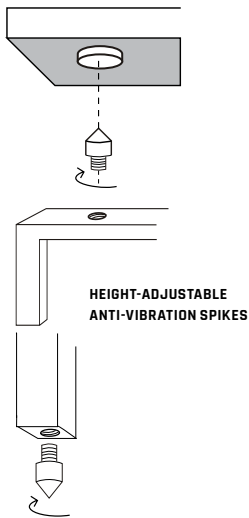

FRONT VIEW

**TECHNICAL DESCRIPTION**

- Overall height: 910 mm;
- Overall width: 560 mm;
- Overall depth: 440 mm;
- Leg profile: 60 x 30 mm;
- Top shelf: 560 x 440 x 30 mm;
- Bottom shelves: 490 x 440 x 30 mm;
- Usable distance between the shelves (moving upwards): 360, 260, 250 mm;
- Maximum load for each shelf: up to 100 kg (total: 400 kg)
- Ballast: quartz sand

**A COMPLETE SET INCLUDES**

- 1 steel frame;
- 4 shelves (MDF/HDF/MDF SANDWICH STRUCTURE);
- 20 height-adjustable spikes;
- 16 anti-vibration separating disks;
- 4 massive anti-scratch disks protecting the floor
- Ballast: quartz sand

BALLAST (QUARTZ SAND)

HEIGHT-ADJUSTABLE ANTI-VIBRATION SPIKES

4-level, four-legged stand, with sandwich structure silver finish shelves. The frame contains quartz sand ballast (bolted holes in the legs make it possible to change the amount and kind of ballast). The frame color: silver.

Anti-vibration stands are designed for high end audio components. The frame has been tuned by a suitable combination of alloy steel and high-fiber content steel. The frame consist of extra-strong legs made of carbon steel S235JR (which is used for load-bearing stuctures subject to heavy dynamic load, e.g. in cranes) connected by crosspieces made from higher-strength alloy steel S355. Adjustable anti-vibration spikes are used for for high-precision leveling.

**120 kg**

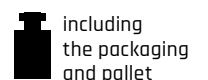



modification according to individual requests  
size change, kind of frame,  
kind of shelves, kind of decoupling



SYSTEM



<https://www.rogoz-audio.com>  
[office@rogoz-audio.com](mailto:office@rogoz-audio.com)  
[januszrogoz@yahoo.pl](mailto:januszrogoz@yahoo.pl)

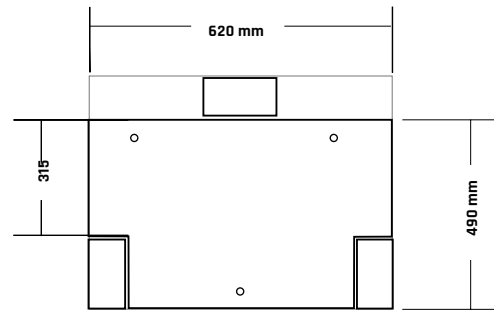
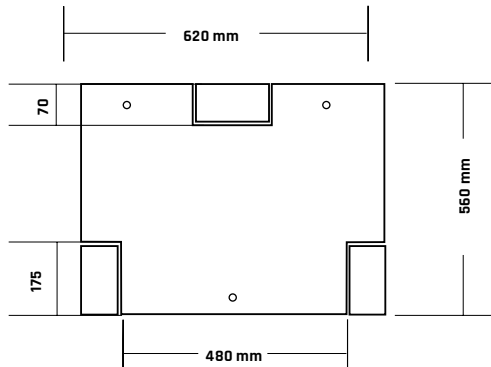

VIEW FROM ABOVE  
top shelf center shelf

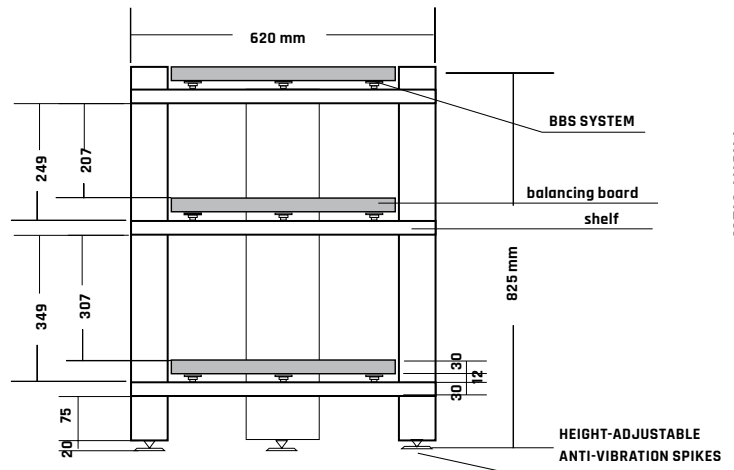
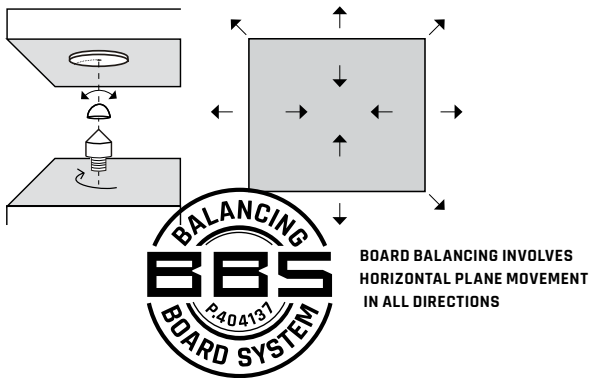

FRONT VIEW

### TECHNICAL DESCRIPTION

- Overall height: 825 mm
- Overall width: 620 mm
- Overall depth: 560 mm
- Leg profile: 165 x 60 mm
- Top shelf: 480 x 560 x 30 + 30 mm
- Center and bottom shelves: 480 x 490 x 30 + 30 mm
- Usable distance between the shelves (moving upwards): 307, 207 mm
- Maximum load for each shelf: up to 100 kg (total: 300 kg)

### A COMPLETE SET INCLUDES

- 1 stand (shelves - sandwich structure MDF/HDF/ MDF)
- 3 height-adjustable spikes
- BBS between shelves
- 3 massive anti-scratch disks protecting the floor

3-level, three-legged stand with glossy piano finish. Double shelves 2 x 30 mm thick are separated by BBS. BBS has kinematic and dynamic qualities which enable isolated masses to "float" to the sides relative to the system axis, maintaining point support at the same time. BBS also makes it possible to level the stand shelves. Anti-vibration stands are designed for high end audio components.

The audio stand structure incorporates a new proprietary Rogoz Audio antivibration system, BBS (Balancing Board System, Patent P.404137). The system consists of a threaded, height-adjustable spike made of high-fiber-content steel alloy, on top of which two elements are placed, each with an inner bearing. An intermediary (middle) element is made of carbon fiber and supports another element, a steel bearing inserted into the shelf. Point contact between the steel spike and the carbon intermediary element prevents movement of either element relative to its axis, but it allows pendular motion. Meanwhile, the contact between the intermediary element and the bearing inserted into the shelf allows restricted rolling motion and sliding motion. Consequently, the advantages of spike point support (contact area has been minimized and kinetic energy turns into heat) have been combined with the effects of deadening vibrations owing to sliding friction and rolling resistance.

110 kg

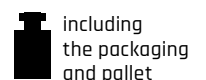



modification according to individual requests  
size change, kind of frame,  
kind of shelves, kind of decoupling



SYSTEM



<https://www.rogoz-audio.com>  
[office@rogoz-audio.com](mailto:office@rogoz-audio.com)  
[januszrogoz@yahoo.pl](mailto:januszrogoz@yahoo.pl)

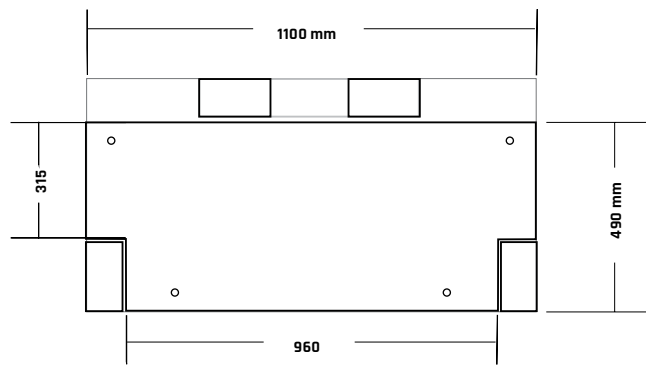
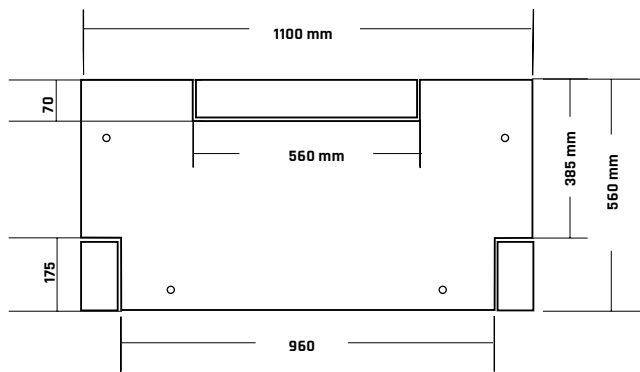

VIEW FROM ABOVE  
top shelf center shelf

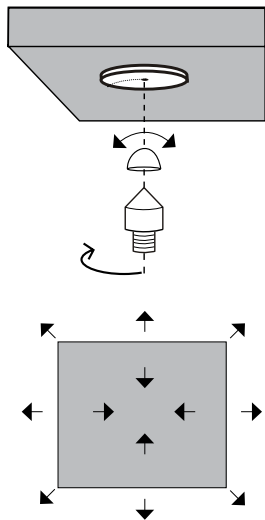

BOARD BALANCING INVOLVES  
HORIZONTAL PLANE MOVEMENT  
IN ALL DIRECTIONS

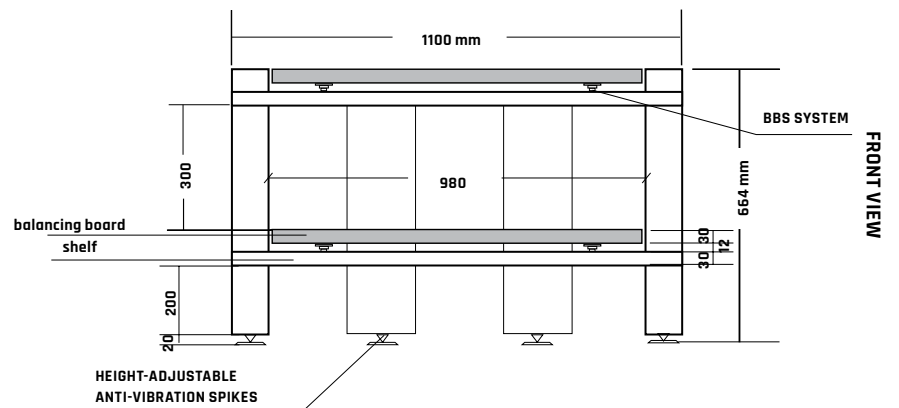

FRONT VIEW

**TECHNICAL DESCRIPTION**

- Overall height: 684 mm
- Overall width: 1100 mm
- Overall depth: 560 mm
- Leg profile: 165 x 60 mm
- Top shelf: 960 x 560 x 30 + 30 mm
- Center and bottom shelves: 960 x 490 x 30 + 30 mm
- Usable distance between the shelves (moving upwards): 300 mm
- Maximum load for each shelf: up to 100 kg (total: 200 kg)(total: 200 kg)

**A COMPLETE SET INCLUDES**

- 1 stand (shelves - sandwich structure MDF/HDF/ MDF)
- 4 height-adjustable spikes
- BBS between shelves
- 4 massive anti-scratch disks protecting the floor

2-level, four-legged stand with glossy piano finish. Double shelves 2 x 30 mm thick are separated by BBS. BBS has kinematic and dynamic qualities which enable isolated masses to “float” to the sides relative to the system axis, maintaining point support at the same time. BBS also makes it possible to level the stand shelves. Anti-vibration stands are designed for high end audio components.

The audio stand structure incorporates a new proprietary Rogoz Audio antivibration system, BBS (Balancing Board System, Patent P.404137). The system consists of a threaded, height-adjustable spike made of high-fiber-content steel alloy, on top of which two elements are placed, each with an inner bearing. An intermediary (middle) element is made of carbon fiber and supports another element, a steel bearing inserted into the shelf. Point contact between the steel spike and the carbon intermediary element prevents movement of either element relative to its axis, but it allows pendular motion. Meanwhile, the contact between the intermediary element and the bearing inserted into the shelf allows restricted rolling motion and sliding motion. Consequently, the advantages of spike point support (contact area has been minimized and kinetic energy turns into heat) have been combined with the effects of deadening vibrations owing to sliding friction and rolling resistance.

**160 kg**

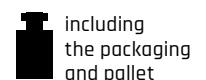

**BEST of the BEST** High Fidelity.pl  
Audio • Video • Show • 2015



modification according to individual requests  
size change, kind of frame,  
kind of shelves, kind of decoupling



SYSTEM



<https://www.rogoz-audio.com>  
[office@rogoz-audio.com](mailto:office@rogoz-audio.com)  
[januszrogoz@yahoo.pl](mailto:januszrogoz@yahoo.pl)

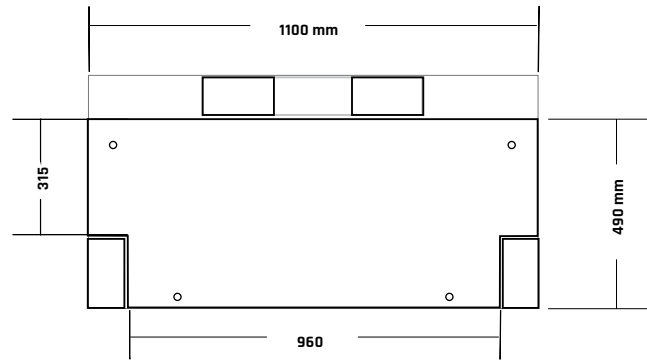
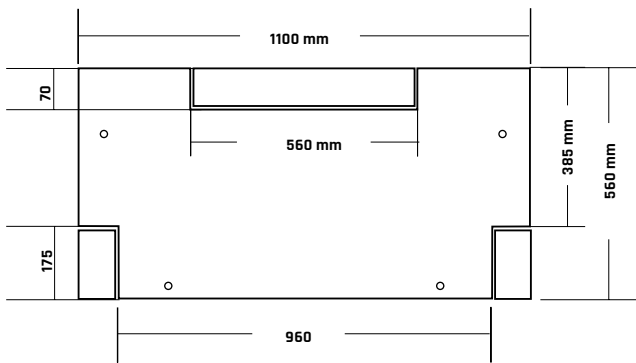

VIEW FROM ABOVE  
top shelf center shelf

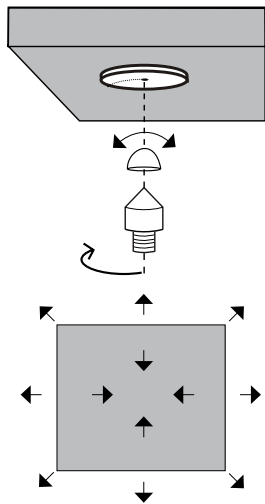

BOARD BALANCING INVOLVES HORIZONTAL PLANE MOVEMENT IN ALL DIRECTIONS

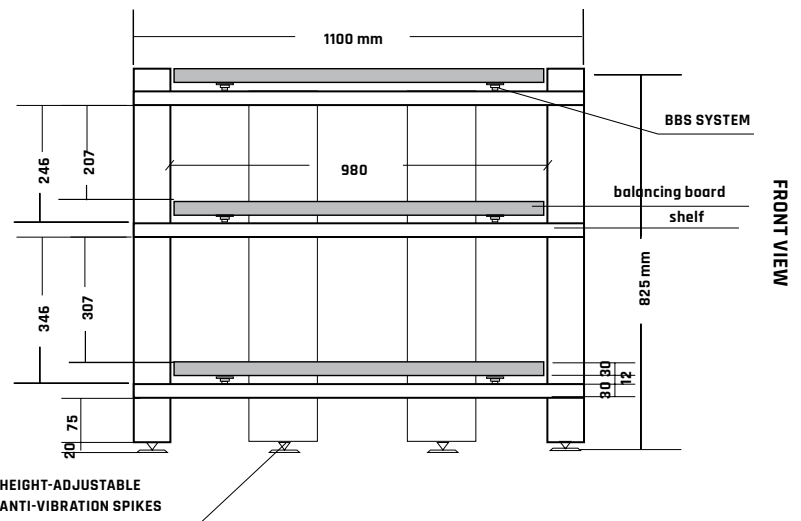

FRONT VIEW

### TECHNICAL DESCRIPTION

- Overall height: 825 mm
- Overall width: 1100 mm
- Overall depth: 560 mm
- Leg profile: 165 x 60 mm
- Top shelf: 960 x 560 x 30 + 30 mm
- Center and bottom shelves: 960 x 490 x 30 + 30 mm
- Usable distance between the shelves (moving upwards): 307, 207 mm
- Maximum load for each shelf: up to 100 kg (total: 300 kg)

### A COMPLETE SET INCLUDES

- 1 stand (shelves - sandwich structure MDF/HDF/ MDF)
- 4 height-adjustable spikes
- BBS between shelves
- 4 massive anti-scratch disks protecting the floor

3-level, four-legged stand with glossy piano finish. Double shelves 2 x 30 mm thick are separated by BBS. BBS has kinematic and dynamic qualities which enable isolated masses to "float" to the sides relative to the system axis, maintaining point support at the same time. BBS also makes it possible to level the stand shelves. Anti-vibration stands are designed for high end audio components.

The audio stand structure incorporates a new proprietary Rogoz Audio antivibration system, BBS (Balancing Board System, Patent P.404137). The system consists of a threaded, height-adjustable spike made of high-fiber-content steel alloy, on top of which two elements are placed, each with an inner bearing. An intermediary (middle) element is made of carbon fiber and supports another element, a steel bearing inserted into the shelf. Point contact between the steel spike and the carbon intermediary element prevents movement of either element relative to its axis, but it allows pendular motion. Meanwhile, the contact between the intermediary element and the bearing inserted into the shelf allows restricted rolling motion and sliding motion. Consequently, the advantages of spike point support (contact area has been minimized and kinetic energy turns into heat) have been combined with the effects of deadening vibrations owing to sliding friction and rolling resistance.

**200 kg**

 including the packaging and pallet



modification according to individual requests  
size change, kind of frame,  
kind of shelves, kind of decoupling



<https://www.rogoz-audio.com>  
[office@rogoz-audio.com](mailto:office@rogoz-audio.com)  
[januszrogoz@yahoo.pl](mailto:januszrogoz@yahoo.pl)

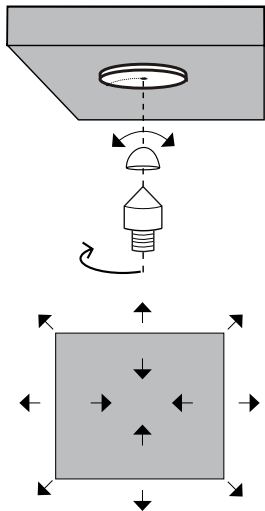
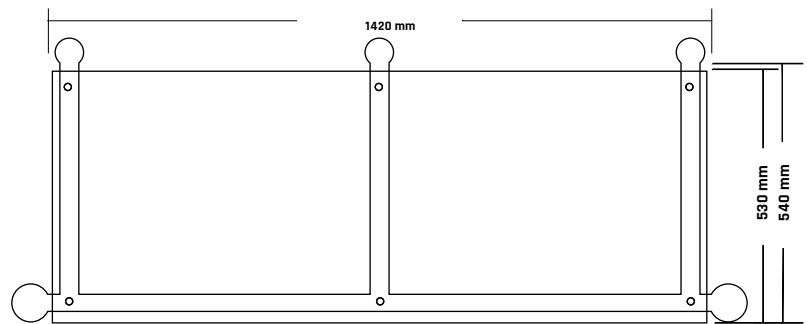
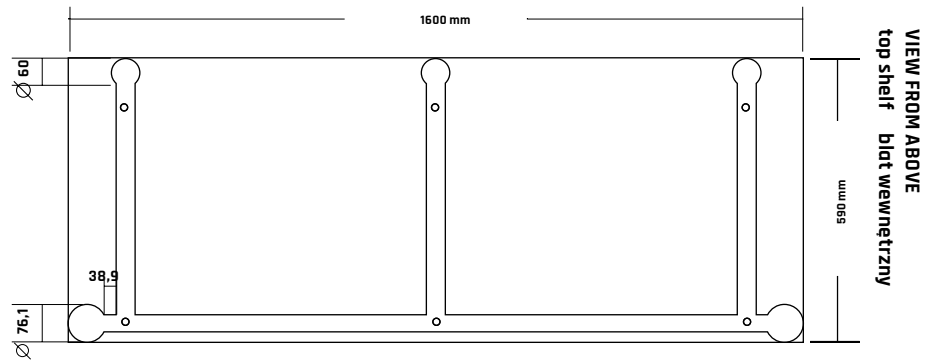

BOARD BALANCING INVOLVES HORIZONTAL PLANE MOVEMENT IN ALL DIRECTIONS

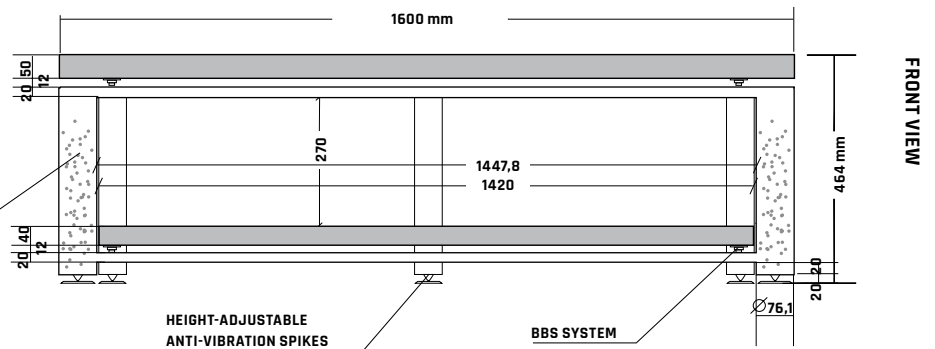

### TECHNICAL DESCRIPTION

- Overall height: 464 mm
- Overall width: 1600 mm
- Overall depth: 590 mm
- Leg profile: steel pipes (Ø 76.1 mm - front, Ø 60 mm - back)
- Top shelf: 1600 x 590 x 50 mm
- Bottom shelves: 1420 x 530 x 40 mm
- Usable distance between the shelves (moving upwards): 270 mm
- Maximum load for each shelf: up to 200 kg (total: 400 kg)
- Ballast: quartz sand

### A COMPLETE SET INCLUDES

- 1 steel frame
- 2 shelves (MDF/HDF/MDF - sandwich structure)
- 5 height-adjustable spikes
- BBS under each shelf
- 5 massive anti-scratch disks protecting the floor

2-level, five-legged stand with glossy piano white finish shelves. The frame contains quartz sand ballast (bolted holes in the legs make it possible to change the amount and kind of ballast). The frame color: piano white (glossy). The top shelf is 50 mm thick with sandwich structure and is optimal for analog gramophones and digital signal sources. The bottom shelf is 40 mm thick and have a similar structure. All the shelves are separated from the stand frame by the Balancing Board System. BBS has kinematic and dynamic qualities which enable isolated masses to "float" to the sides relative to the system axis, maintaining point support at the same time. BBS also makes it possible to level the stand shelves.

Anti-vibration stands are designed for high end audio components. The frame has been tuned by a suitable combination of alloy steel and high-fiber content steel. The frame consist of extra-strong legs made of carbon steel S235JR (which is used for load-bearing stuctures subject to heavy dynamic load, e.g. in cranes) connected by crosspieces made from higher-strength alloy steel S355. Adjustable anti-vibration spikes are used for for high-precision leveling.

180 kg

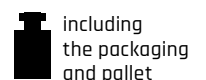



modification according to individual requests  
size change, kind of frame,  
kind of shelves, kind of decoupling



<https://www.rogoz-audio.com>  
[office@rogoz-audio.com](mailto:office@rogoz-audio.com)  
[januszrogoz@yahoo.pl](mailto:januszrogoz@yahoo.pl)

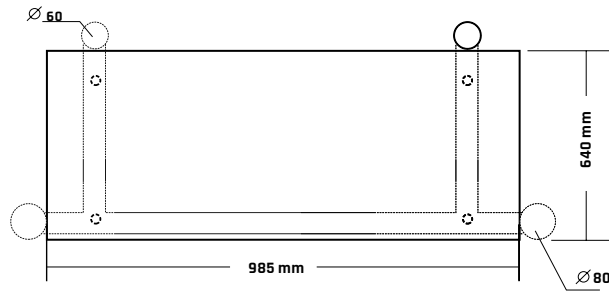
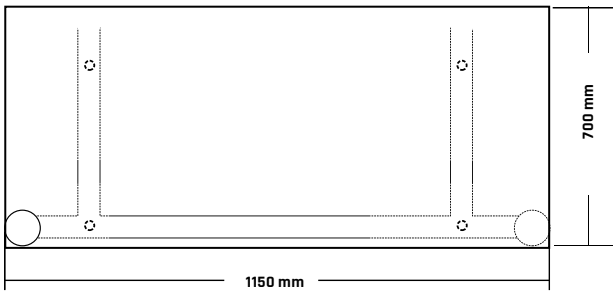

VIEW FROM ABOVE  
top shelf center shelf

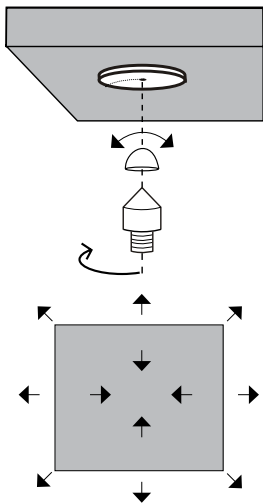

BOARD BALANCING INVOLVES  
HORIZONTAL PLANE MOVEMENT  
IN ALL DIRECTIONS

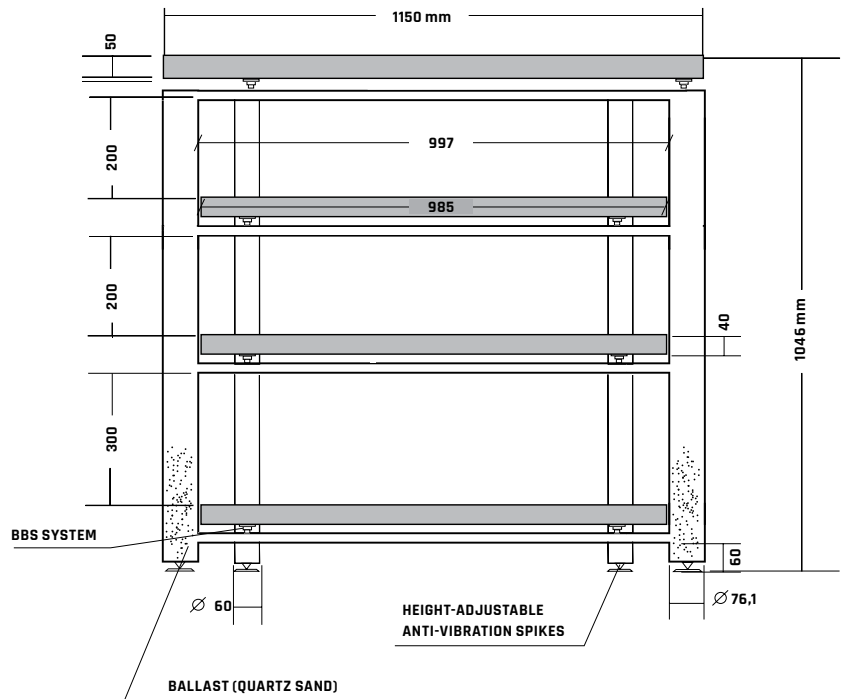

FRONT VIEW

### TECHNICAL DESCRIPTION

- Overall height: 1058 mm
- Overall width: 1150 mm
- Overall depth: 700 mm
- Leg profile: steel pipes (Ø 76.1 mm - front, Ø 60 mm - back)
- Top shelf: 1150 x 700 x 50 mm
- Center and bottom shelves: 985 x 640 x 40 mm
- Usable distance between the shelves (moving upwards): 300, 200, 200 mm
- Maximum load for each shelf: up to 150 kg (total: 600 kg)
- Ballast: quartz sand

### A COMPLETE SET INCLUDES

- 1 steel frame
- 4 shelves (MDF/HDF/MDF/wood veneer - sandwich structure)
- 4 height-adjustable spikes
- BBS under each shelf
- 4 massive anti-scratch disks protecting the floor

4-level, four-legged stand with glossy piano finish shelves (natural sappele mahogany veneer; dyed wood; No. 25-25) The frame contains quartz sand ballast (bolted holes in the legs make it possible to change the amount and kind of ballast). The frame color: satin black. The top shelf is 50 mm thick with sandwich structure and is optimal for analog gramophones and digital signal sources. The middle and bottom shelves are 40 mm thick and have a similar structure. All the shelves are separated from the stand frame by the Balancing Board System. BBS has kinematic and dynamic qualities which enable isolated masses to "float" to the sides relative to the system axis, maintaining point support at the same time. BBS also makes it possible to level the stand shelves.

Anti-vibration stands are designed for high end audio components. The frame has been tuned by a suitable combination of alloy steel and high-fiber content steel. The frame consist of extra-strong legs made of carbon steel S235JR (which is used for load-bearing stuctures subject to heavy dynamic load, e.g. in cranes) connected by crosspieces made from higher-strength alloy steel S355. Adjustable anti-vibration spikes are used for for high-precision leveling.

200 kg

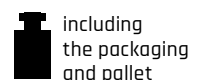

**audiostereo**

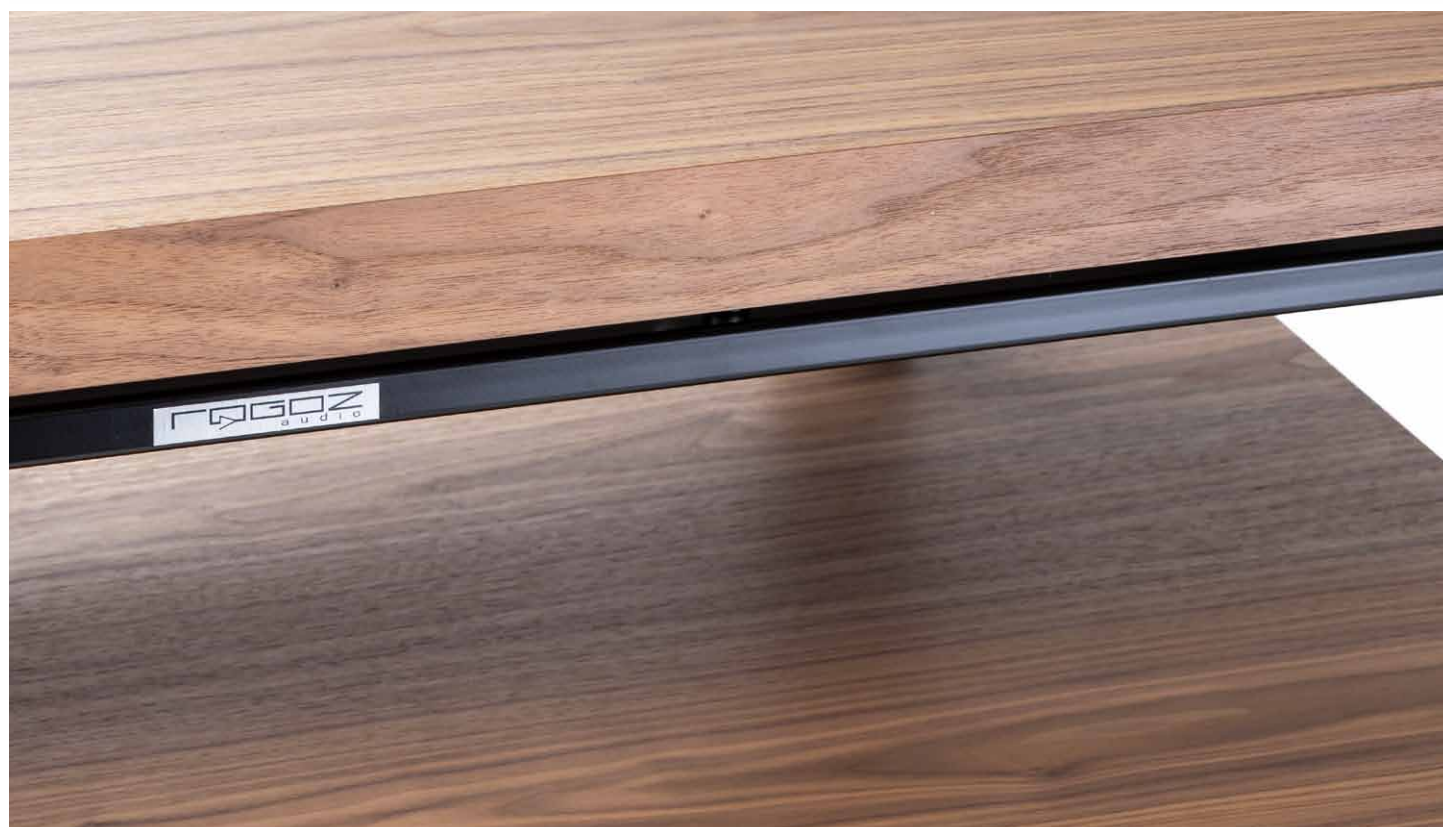

modification according to individual requests  
size change, kind of frame,  
kind of shelves, kind of decoupling



SYSTEM



<https://www.rogoz-audio.com>  
[office@rogoz-audio.com](mailto:office@rogoz-audio.com)  
[januszrogoz@yahoo.pl](mailto:januszrogoz@yahoo.pl)

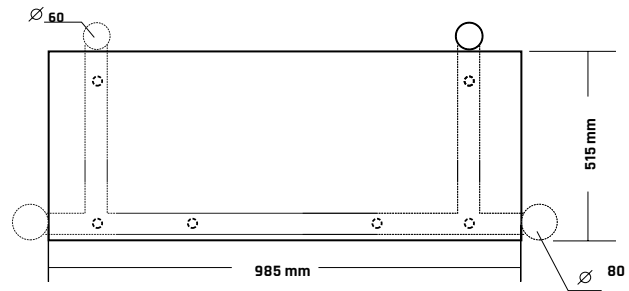
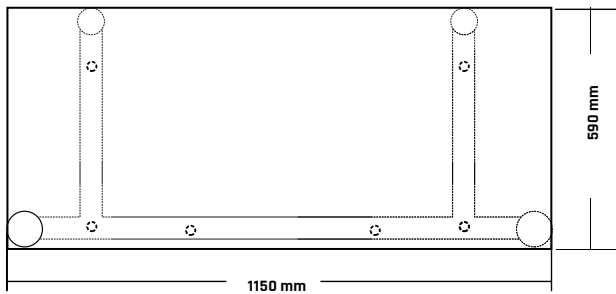

VIEW FROM ABOVE  
top shelf - center shelf

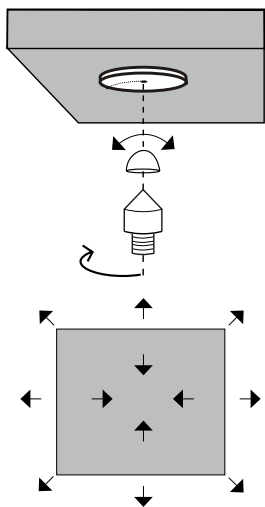

BOARD BALANCING INVOLVES  
HORIZONTAL PLANE MOVEMENT  
IN ALL DIRECTIONS

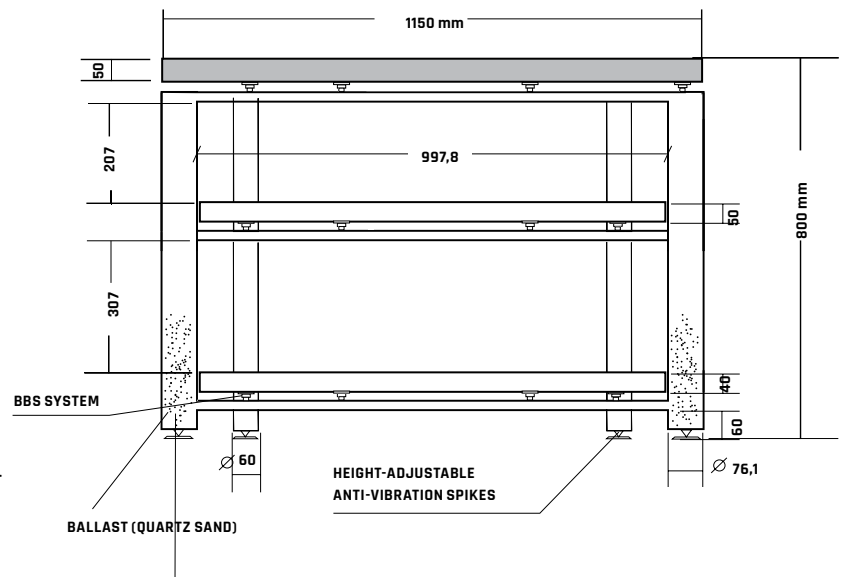

FRONT VIEW

### TECHNICAL DESCRIPTION

- Overall height: 800 mm
- Overall width: 1150 mm
- Overall depth: 590 mm
- Leg profile: steel pipes (Ø 76.1 mm - front, Ø 60 mm - back)
- Top shelf: 1150 x 590 x 50 mm
- Center and bottom shelves: 985 x 515 x 40 mm
- Usable distance between the shelves (moving upwards): 307, 207 mm
- Maximum load for each shelf: up to 150 kg (total: 450 kg)
- Ballast: quartz sand

### A COMPLETE SET INCLUDES

- 1 steel frame
- 3 shelves (MDF/HDF/MDF/wood veneer - sandwich structure)
- 4 height-adjustable spikes
- BBS under each shelf
- 4 massive anti-scratch disks protecting the floor

3-level, four-legged stand with shelves covered in natural wood veneer (american walnut - oiled, matt). The frame contains quartz sand ballast (bolted holes in the legs make it possible to change the amount and kind of ballast). The frame color: satin black. The top shelf is 50 mm thick with sandwich structure and is optimal for analog gramophones and digital signal sources. The middle and bottom shelves are 40 mm thick and have a similar structure. All the shelves are separated from the stand frame by the Balancing Board System. BBS has kinematic and dynamic qualities which enable isolated masses to "float" to the sides relative to the system axis, maintaining point support at the same time. BBS also makes it possible to level the stand shelves.

Anti-vibration stands are designed for high end audio components. The frame has been tuned by a suitable combination of alloy steel and high-fiber content steel. The frame consist of extra-strong legs made of carbon steel S235JR (which is used for load-bearing sturctures subject to heavy dynamic load, e.g. in cranes) connected by crosspieces made from higher-strength alloy steel S355. Adjustable anti-vibration spikes are used for for high-precision leveling.

160 kg

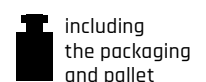

including  
the packaging  
and pallet



modification according to individual requests  
size change, kind of frame,  
kind of shelves, kind of decoupling



<https://www.rogoz-audio.com>  
[office@rogoz-audio.com](mailto:office@rogoz-audio.com)  
[januszrogoz@yahoo.pl](mailto:januszrogoz@yahoo.pl)

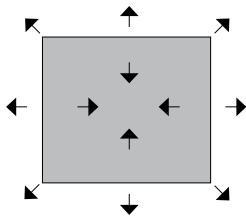
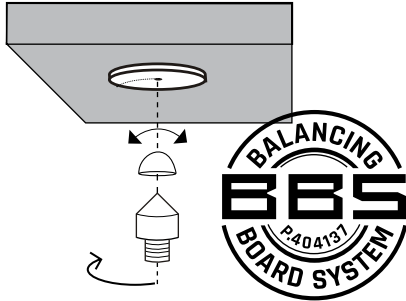

**BOARD BALANCING INVOLVES HORIZONTAL PLANE MOVEMENT IN ALL DIRECTIONS**

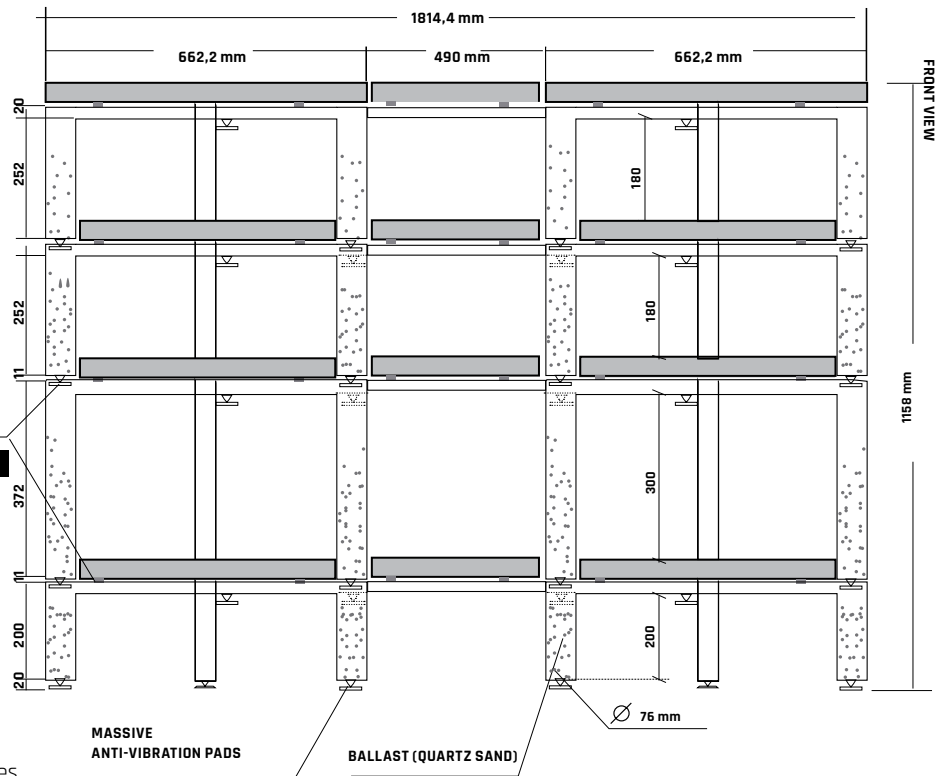
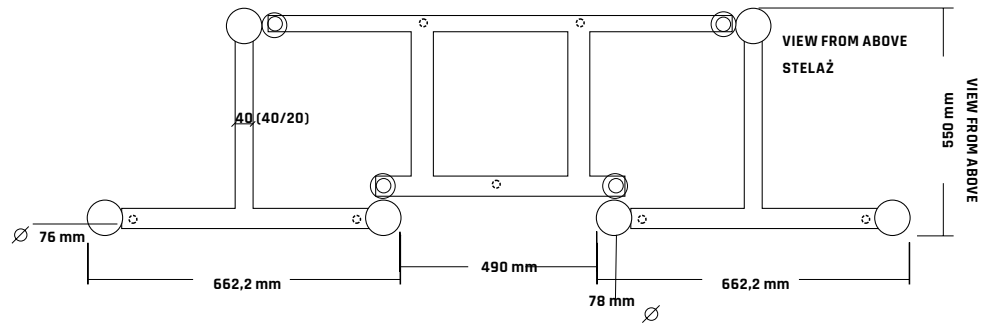

### TECHNICAL DESCRIPTION

- Maximum height - 1158 mm;
- Overall width: - 1814,4 mm;
- Overall depth: - 550 mm;
- Leg profile: steel pipes (Ø 76 mm - front/back);
- Top shelves: (A modules) - 662,2 x 550 x 50 mm;
- Lower shelves (A modules): 490 x 460 x 40 mm;
- Top shelves (B modules) - 490 x 550 x 50 mm;
- Lower shelves (B modules) - 490 x 550 x 40 mm;
- Usable distance between the A modules (moving upwards) - 300, 180, 180 mm (the order of modules may be changed);
- Usable distance between the B modules (moving upwards) - 300, 180, 180 mm (the order of modules may be changed);
- Ballast: quartz sand;
- Net weight - 160 kg;
- Maximum load for each A module - up to 80 kg (total: 640 kg);
- Maximum load for each B module - up to 25 kg

### A COMPLETE SET INCLUDES

- 8 steel frames of the A module
- 4 steel frames of the B module
- 12 shelves (MDF/HDF/MDF/wood veneer - sandwich structure)
- 43 height-adjustable spikes
- 40 massive separating pads

X-level modular stand (12-modular version presented here) with 40 and 50 mm thick shelves covered in natural wood veneer (birch burl). The frame color is golden brass. The frame contains quartz sand ballast (bolted holes in the legs make it possible to change the amount and kind of ballast). The structure consists of two kinds of separate modules (A and B). The structure consists of individual modules, which can be placed vertically (one on top of another) or side by side. The modules are separated by means of height-adjustable spikes and anti-vibration pads. The original set may be expanded by adding extra modules.

Upon customer request, it is possible to change the number of modules, their size and color, and the kind of decoupling.

Module A consists of a shelf supported by a frame with three round legs, which have one-sided (left- or right-sided, depending on which option is selected) handles of a system used to assemble B modules.

Module B consists of a shelf supported by a flat frame, which is to be assembled between two A-type modules (one of which needs to have right-sided handles, and the other left-sided ones).

240 kg

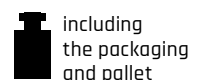



**STEREO**

**BEST PRODUCT 2017** High Fidelity.pl

**pf**  
positive feedback

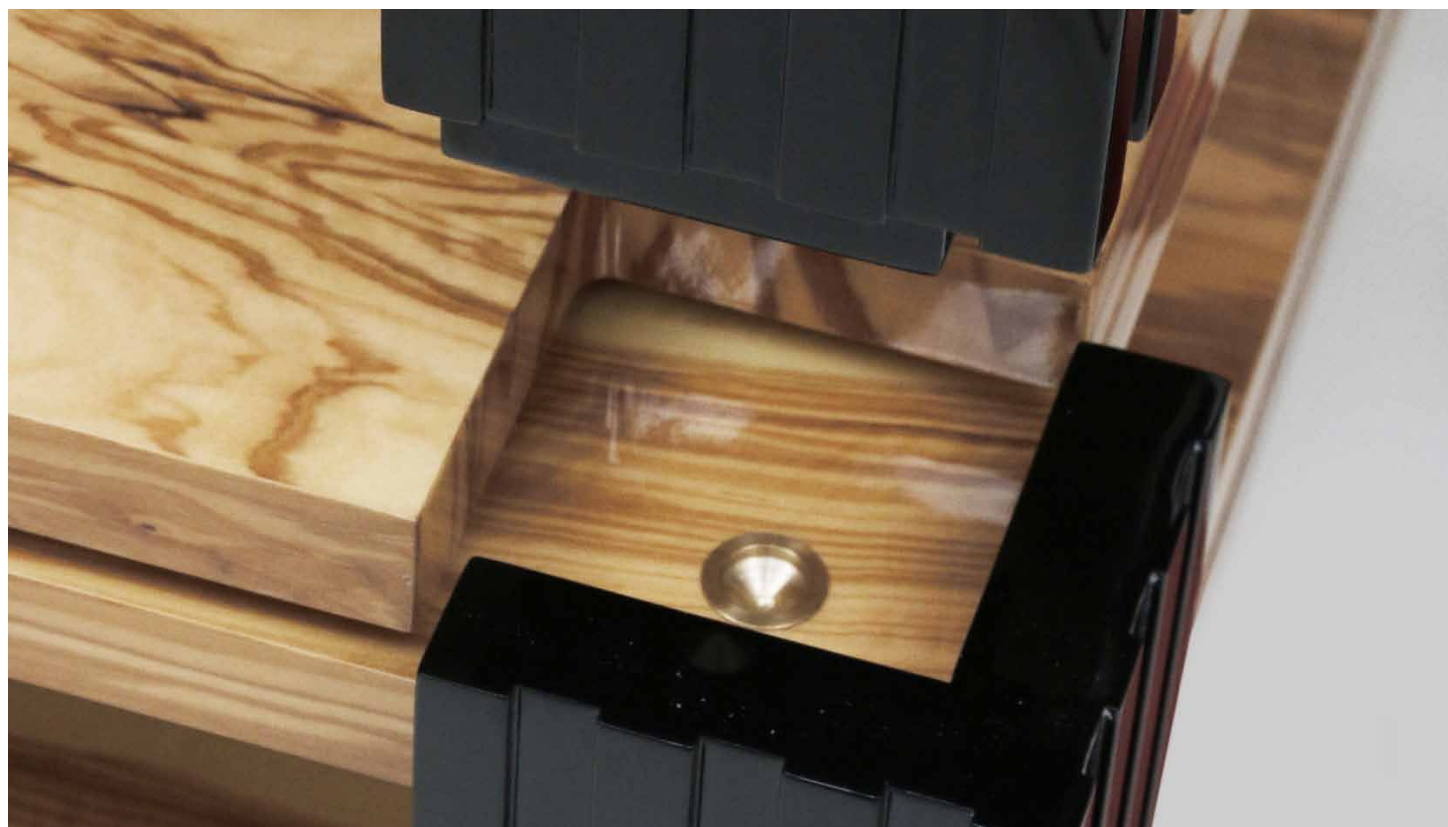

modification according to individual requests  
size change, kind of frame,  
kind of shelves, kind of decoupling



<https://www.rogoz-audio.com>  
office@rogoz-audio.com  
januszrogoz@yahoo.pl

**WARNING:** do not move or carry the furniture with a load. When setting up or moving the furniture, hold it by the supporting tabletop (never by the legs). This audio stand is designed for static vertical loads and no lateral forces should be exerted on it.

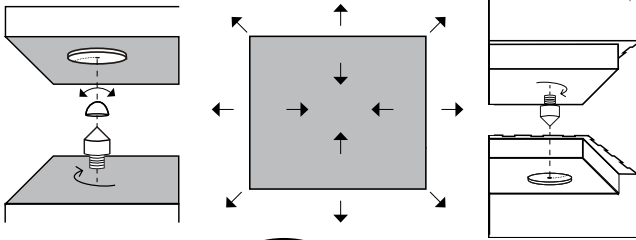
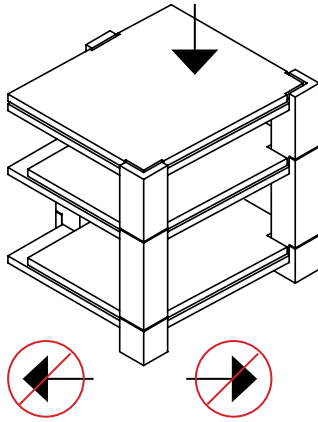

BOARD BALANCING INVOLVES HORIZONTAL PLANE MOVEMENT IN ALL DIRECTIONS

MASSIVE ANTI-VIBRATION PADS

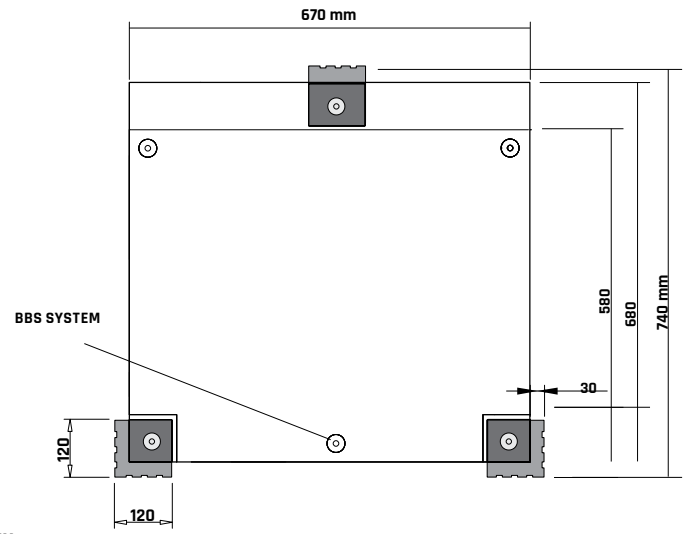

VIEW FROM ABOVE

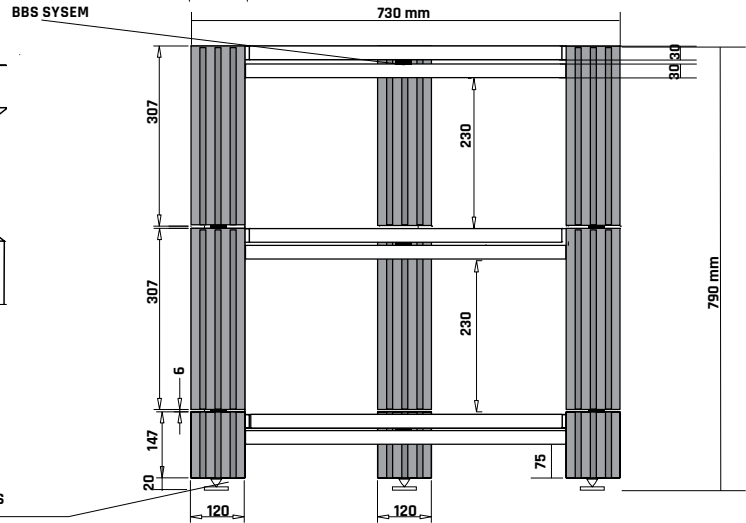

FRONT VIEW

### TECHNICAL DESCRIPTION

- Overall height: 790 mm;
- Overall width: 730mm;
- Overall depth: 740 mm;
- Leg profile: 120 x 120 mm;
- Top shelf: 670 x 680 x 30 + 30 mm;
- Center and bottom shelves: 490 x 580 x 30 + 30 mm;
- Usable distance between the shelves (moving upwards): 230, 230 mm;
- Maximum load for each shelf: up to 80 kg (total: 240 kg)

### A COMPLETE SET INCLUDES

- 1 stand (shelves - sandwich structure MDF/HDF/ MDF/wood veneer);
- 9 height-adjustable spikes
- BBS between shelves
- 3 massive anti-scratch disks protecting the floor

3-level, three-legged modular stand, with multi-layer shelf structure. The shelves are covered with natural wood veneer (in the version shown, it is high gloss olive wood). The legs have a multi-layer structure (in the version shown, they have glossy piano finish). The double shelves are separated by BBS. BBS has kinematic and dynamic qualities which enable isolated masses to "float" to the sides relative to the system axis, maintaining point support at the same time. BBS also makes it possible to level the stand shelves. Anti-vibration stands are designed for high end audio components.

All modules are separated from each other by means of adjustable anti-vibration spikes. The stand consists of three separate modules and can be expanded by adding extra modules.

140 kg

including the packaging and pallet

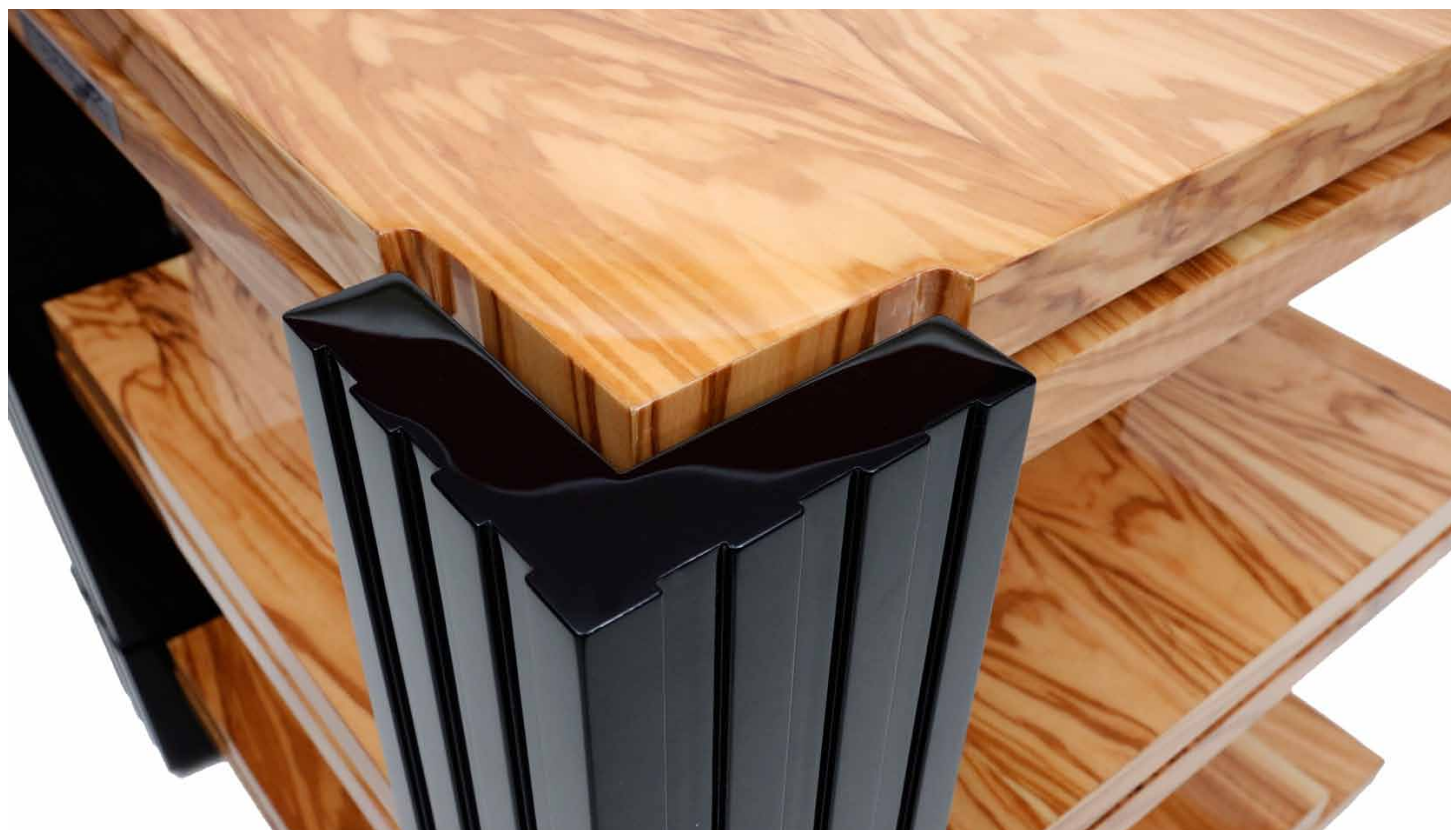

modification according to individual requests  
size change, kind of frame,  
kind of shelves, kind of decoupling



SYSTEM



<https://www.rogoz-audio.com>  
office@rogoz-audio.com  
januszrogoz@yahoo.pl

**WARNING:** do not move or carry the furniture with a load. When setting up or moving the furniture, hold it by the supporting tabletop (never by the legs). This audio stand is designed for static vertical loads and no lateral forces should be exerted on it.

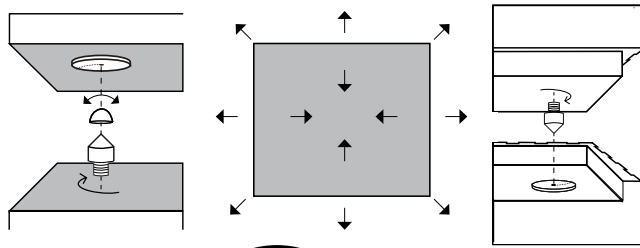
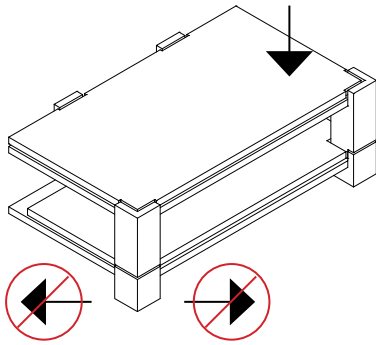

BOARD BALANCING INVOLVES HORIZONTAL PLANE MOVEMENT IN ALL DIRECTIONS

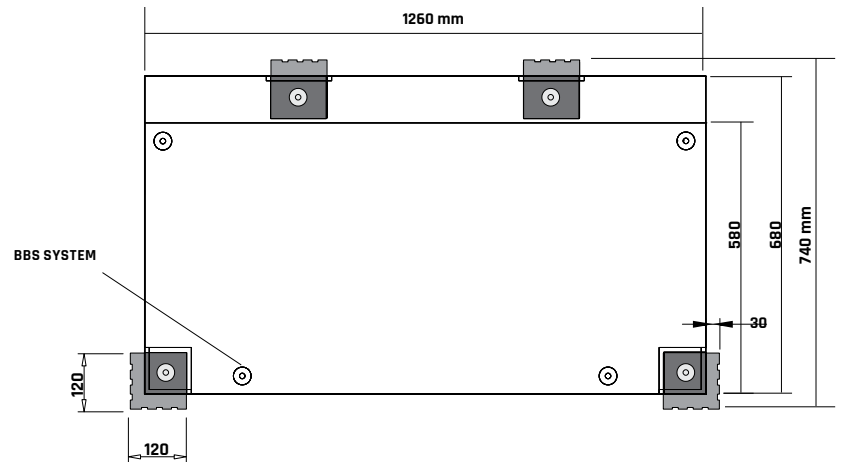

VIEW FROM ABOVE

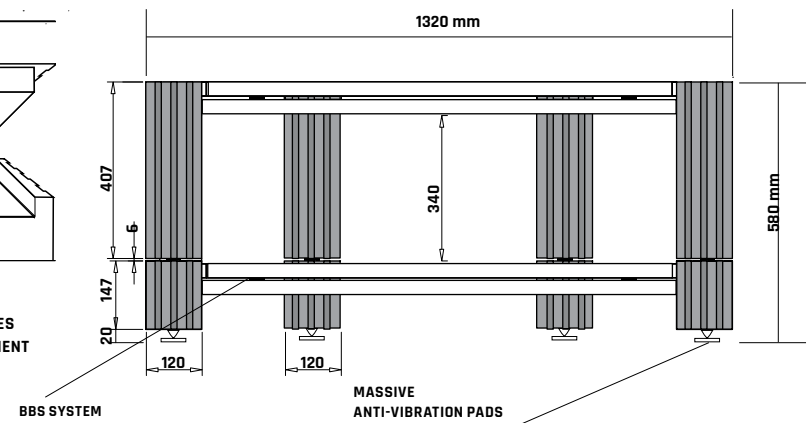

FRONT VIEW

### TECHNICAL DESCRIPTION

- Overall height: 580 mm;
- Overall width: 1320mm;
- Overall depth: 740 mm;
- Leg profile: 120 x 120 mm;
- Top shelf: 1260 x 680 x 30 + 30 mm;
- Bottom shelf: 1060 x 580 x 30 + 30 mm;
- Usable distance between the shelves (moving upwards): 340 mm;
- Maximum load for each shelf: up to 100 kg (total: 200 kg)

### A COMPLETE SET INCLUDES

- 1 stand (shelves - sandwich structure MDF/ HDF/MDF/wood veneer);
- 8 height-adjustable spikes
- BBS between shelves
- 4 massive anti-scratch disks protecting the floor

2-level, four-legged, modular stand, with multi-layer shelf structure. The shelves are covered with natural wood veneer (in the version shown, it is high gloss olive wood). The legs have a multi-layer structure (in the version shown, they have black glossy piano finish). The double shelves are separated by BBS. BBS has kinematic and dynamic qualities which enable isolated masses to "float" to the sides relative to the system axis, maintaining point support at the same time. BBS also makes it possible to level the stand shelves. Anti-vibration stands are designed for high end audio components.

All modules are separated from each other by means of adjustable anti-vibration spikes. The stand consists of three separate modules and can be expanded by adding extra modules.

The audio stand structure incorporates a new proprietary Rogoz Audio antivibration system, BBS (Balancing Board System, Patent P.404137). The system consists of a threaded, height-adjustable spike made of high-fiber-content steel alloy, on top of which two elements are placed, each with an inner bearing. An intermediary (middle) element is made of carbon fiber and supports another element, a steel bearing inserted into the shelf. Point contact between the steel spike and the carbon intermediary element prevents movement of either element relative to its axis, but it allows pendular motion. Meanwhile, the contact between the intermediary element and the bearing inserted into the shelf allows restricted rolling motion and sliding motion. Consequently, the advantages of spike point support (contact area has been minimized and kinetic energy turns into heat) have been combined with the effects of deadening vibrations owing to sliding friction and rolling resistance.

160 kg

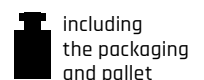



modification according to individual requests  
size change, kind of frame,  
kind of shelves, kind of decoupling



<https://www.rogoz-audio.com>  
[office@rogoz-audio.com](mailto:office@rogoz-audio.com)  
[januszrogoz@yahoo.pl](mailto:januszrogoz@yahoo.pl)

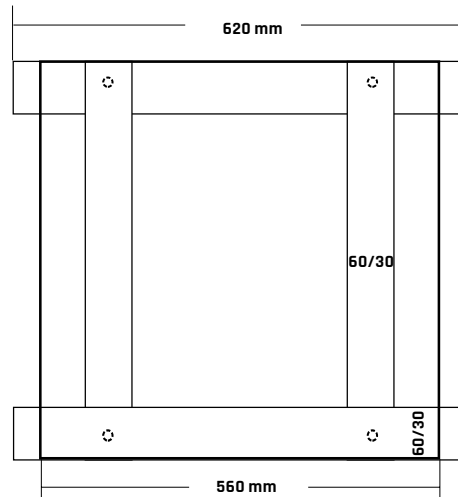
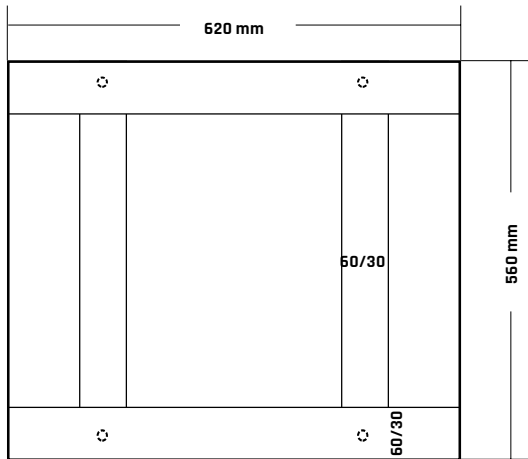

VIEW FROM ABOVE  
top shelf center shelf

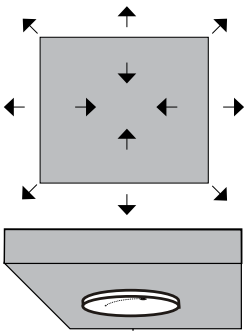

BOARD BALANCING INVOLVES HORIZONTAL PLANE MOVEMENT IN ALL DIRECTIONS

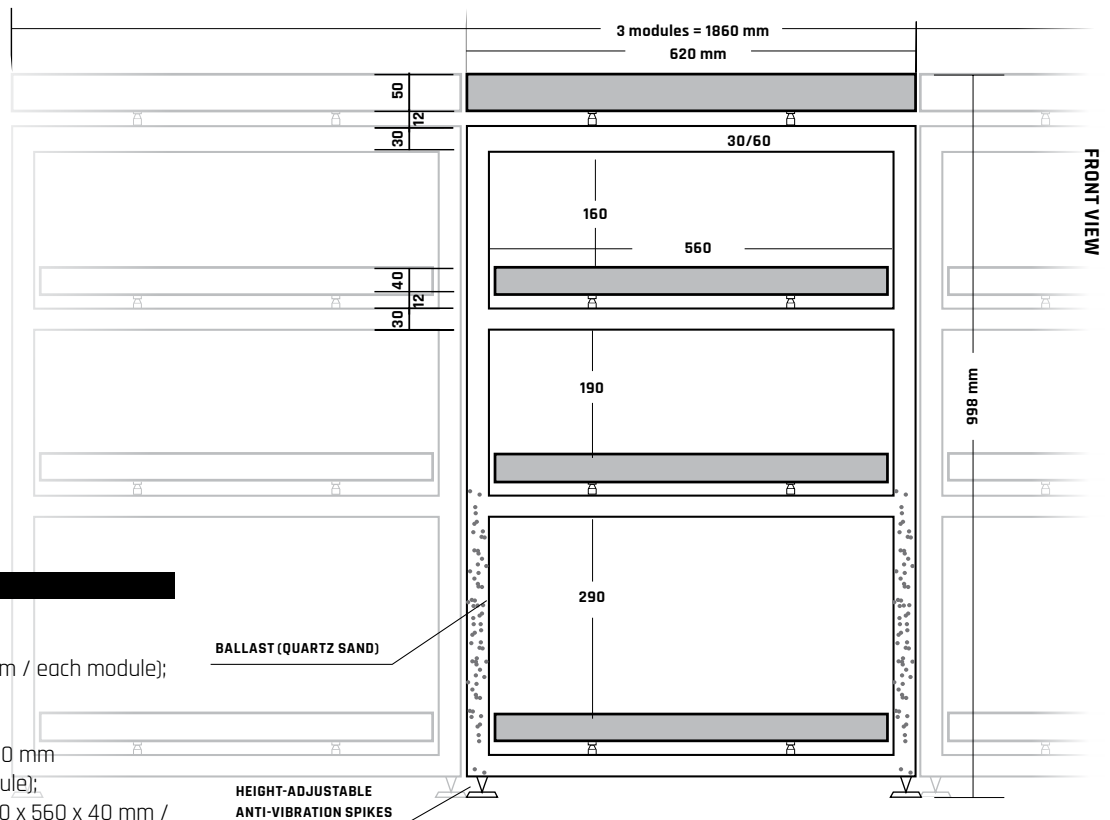

FRONT VIEW

### TECHNICAL DESCRIPTION

- Overall height: 998 mm;
- Overall width: 1860 mm (620 mm / each module);
- Overall depth: 560 mm;
- Leg profile: 60 x 30 mm;
- Top shelves: 1860 mm x 560 x 50 mm (620 x 560 x 50 mm / each module);
- Center and bottom shelves: 560 x 560 x 40 mm / each module;
- Usable distance between the shelves (moving upwards): 290, 190, 160 mm;
- Maximum load for each shelf: up to 150 kg (total: 1800 kg);
- Ballast: quartz sand

### A COMPLETE SET INCLUDES

- 3 steel frames;
- 12 shelves (MDF/HDF/MDF - sandwich structure);
- 12 height-adjustable spikes;
- BBS under each shelf;
- 12 massive anti-scratch disks protecting the floor

BALLAST (QUARTZ SAND)

HEIGHT-ADJUSTABLE ANTI-VIBRATION SPIKES

4-level modular stand (3-modular version presented here) with increased load capacity (150 kg for each shelf; a total of 1,800 kg). The shelves color: glossy piano black. The frame color: black (matt, fine grain). The frame contains quartz sand ballast (bolted holes in the legs make it possible to change the amount and kind of ballast). The structure consists of three individual, 4-level modules which can be placed side by side. The original set may be expanded by adding extra modules.

Upon customer request, it is possible to change the number of modules, their size and color, and the kind of decoupling.

Anti-vibration stands are designed for high end audio components. The frame has been tuned by a suitable combination of alloy steel and high-fiber content steel. The frame consist of extra-strong legs made of carbon steel S235JR (which is used for load-bearing stuctures subject to heavy dynamic load, e.g. in cranes) connected by crosspieces made from higher-strength alloy steel S355. Adjustable anti-vibration spikes are used for for high-precision leveling.

240 kg

